

v1.10



ROBOTIS CO.,LTD. www.robotis.com



Contents

1. Introduction	2
1-1. What is Dynamixel ?	3
1-2. Strong Points of Dynamixel	5
1-3. Specifications of RX-10	6
2. Installation	7
2-1. How to Assemble Frames	8
2-2. Assembling Connector	10
2-3. Wiring	11
2-4. Connection of Main Controller	12
3. Communication with RX-10	14
3-1. Overview of Communication	15
3-2. Instruction Packet	16
3-3. Status Packet (Return Packet)	18
3-4. Control Table	20
3-5. How to Use Packet	32
4. Appendix	44

1. Introduction

1. What is Dynamixel?
2. Strong Points of Dynamixel
3. Specifications of RX-10

1-1. What is Dynamixel ?

New Concept

Dynamixel is a robot-only Smart Actuator with a new concept integrating speed reducer, controller, driver, network function, etc. into one module.

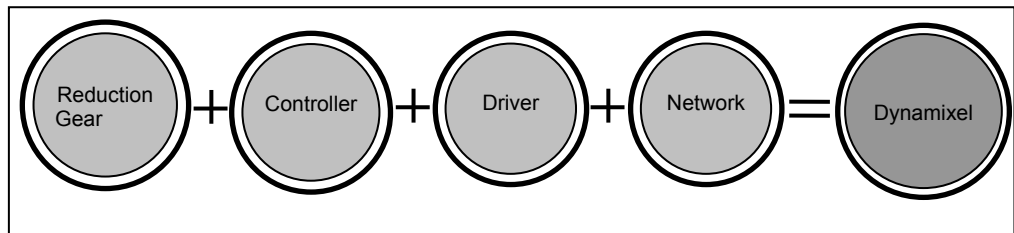

LINE UP

We have Line up of several kinds of Dynamixel applicable numerously according to the kinds and characteristics of robots



All-round Combining Structure Dynamixel is built up with all-round combining structure and it is possible to connect one another with various forms. You can design a robot easily as if assembling a block toy by using option frame for Dynamixel

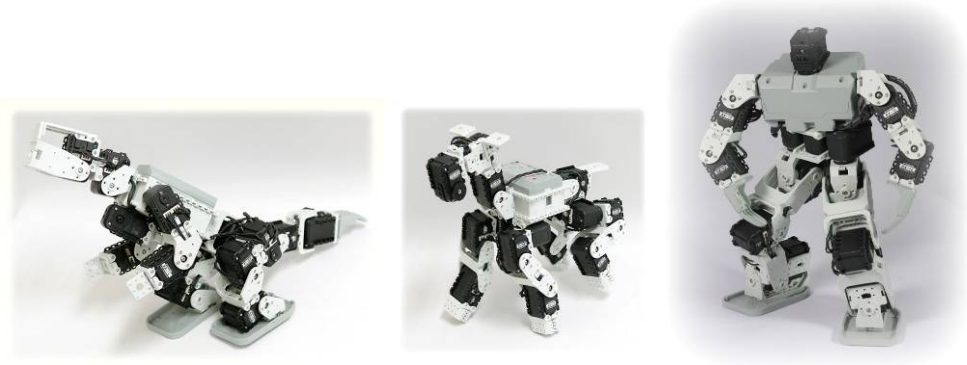

Convenient Wiring Dynamixel is connected with Daisy Chain and it is easy to wire one another.



• Daisy chain link

Network Dynamixel with a unique ID is controlled by Packet communication on a BUS and supports networks such as TTL, RS485, and CAN depending on the type of model.

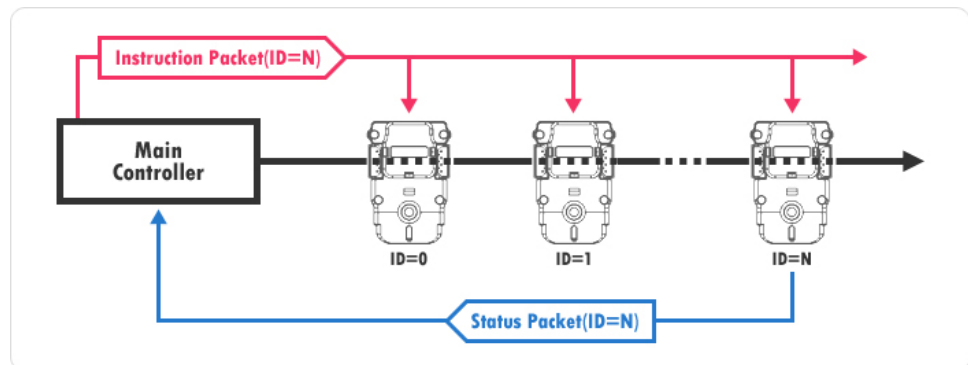

1-2. Strong Points of Dynamixel

Torque	In spite of the compact size, it generates relatively big Torque by way of the efficient speed reduction.
Close Control	It can control location and speed with the resolution of 1024.
Elasticity Setting	It can set up the extent of elasticity when controlling position with Compliance Driving.
Position, Speed	It can read the current position and speed.
Communication	It is easy to wire since it is connected with Daisy chain, and up to 1M BPS of communication speed is supported.
Distribution Control	Since the main processor can set speed, position, compliance, torque, etc. simultaneously with a single command packet, it can control several Dynamixels with a little resource
Physical Intensity	The main body is made of engineering plastic to withstand against strong external force.
Efficiency against External Force	Since a bearing is used at the last axis of the gear, the amount of efficiency reduction is minimal even if strong external force is applied to the axis.
Safety Device	It has the [Alarming] function, which notifies when internal temperature, torque, supplied voltage, etc. deviate from what the user has set, and the [Shut down] function, which allows it to cope with situation by itself.
Status Indicator	It informs the user of ERROR status via LED.

1-3. Specifications of RX-10

	RX-10	
Weight (g)	64.5	
Dimension (mm)	35.6 x 50.6 x 35.5	
Gear Reduction Ratio	1/193	
Applied Voltage (V)	at 10V	at 12V
Final Reduction Stopping Torque (kgf.cm)	10.1	12.1
Speed (Sec/60 degrees)	0.143	0.119

Resolution	0.29°
Running Degree	300°, Endless Turn
Voltage	10V~12V (Recommended voltage: 10.8V)
Max Current	1200mA
Running Temperature	-5°C ~ +85°C
Command Signal	Digital Packet
Protocol	RS485 Asynchronous Serial Communication (8bit, 1stop, No Parity)
Link (Physical)	RS485 Multi Drop Bus
ID	254 ID (0~253)
Communication Speed	7343bps ~ 1 Mbps
Sensing & Measuring	Position, Temperature, Load, Input Voltage, etc.
Material Quality	Full Metal Gear, Engineering Plastic Body
Motor	Maxon RE-MAX
Standby Current	50 mA

2. Installation

1. How to Assemble Frames
2. Assembling Connectors
3. Wiring
4. Connection of Main Controller

2-1. How to Assemble Frames

Optional Frames RX-10 has the following optional frames.

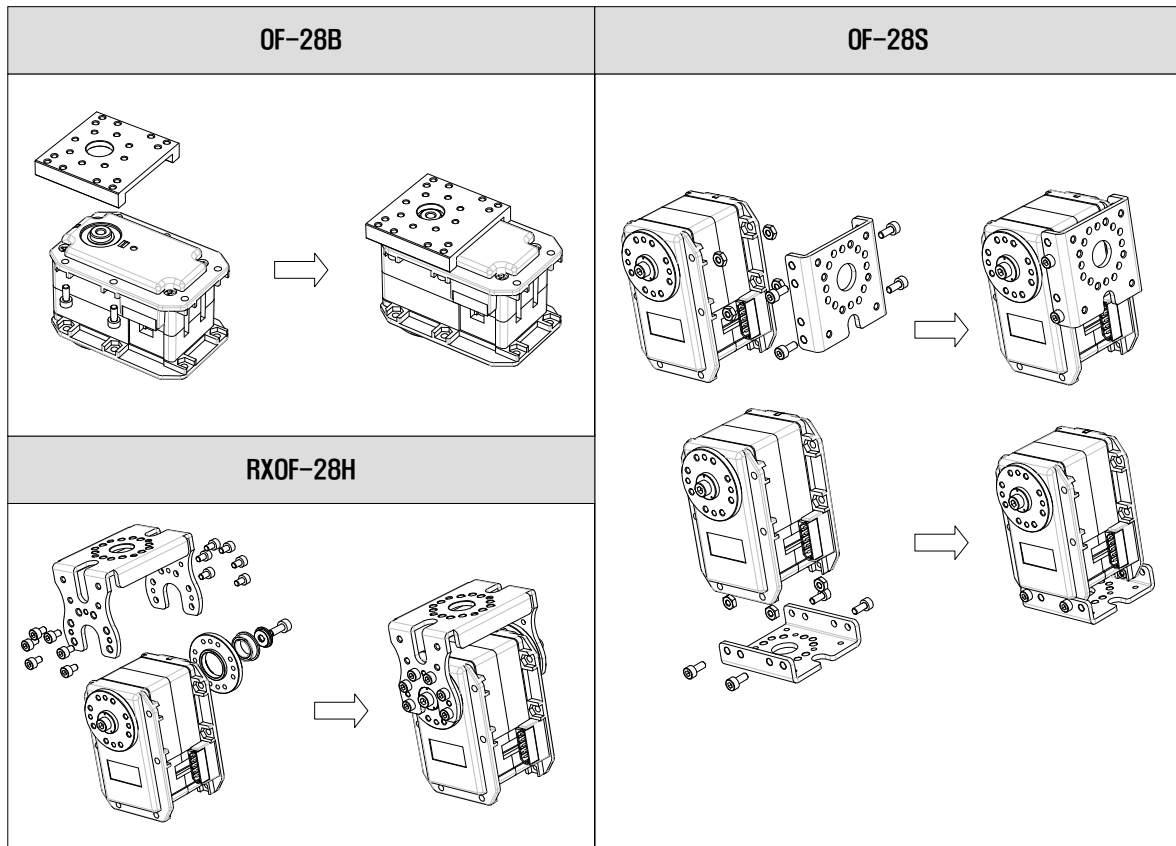

Horn RX-10 has the following kinds of Horns.

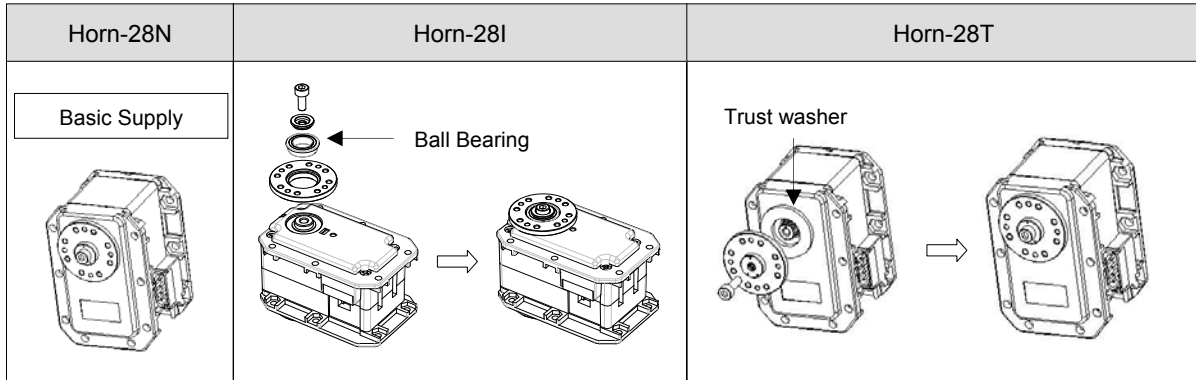

Device Combination The below picture shows examples of combinations by using optional frames and horns.

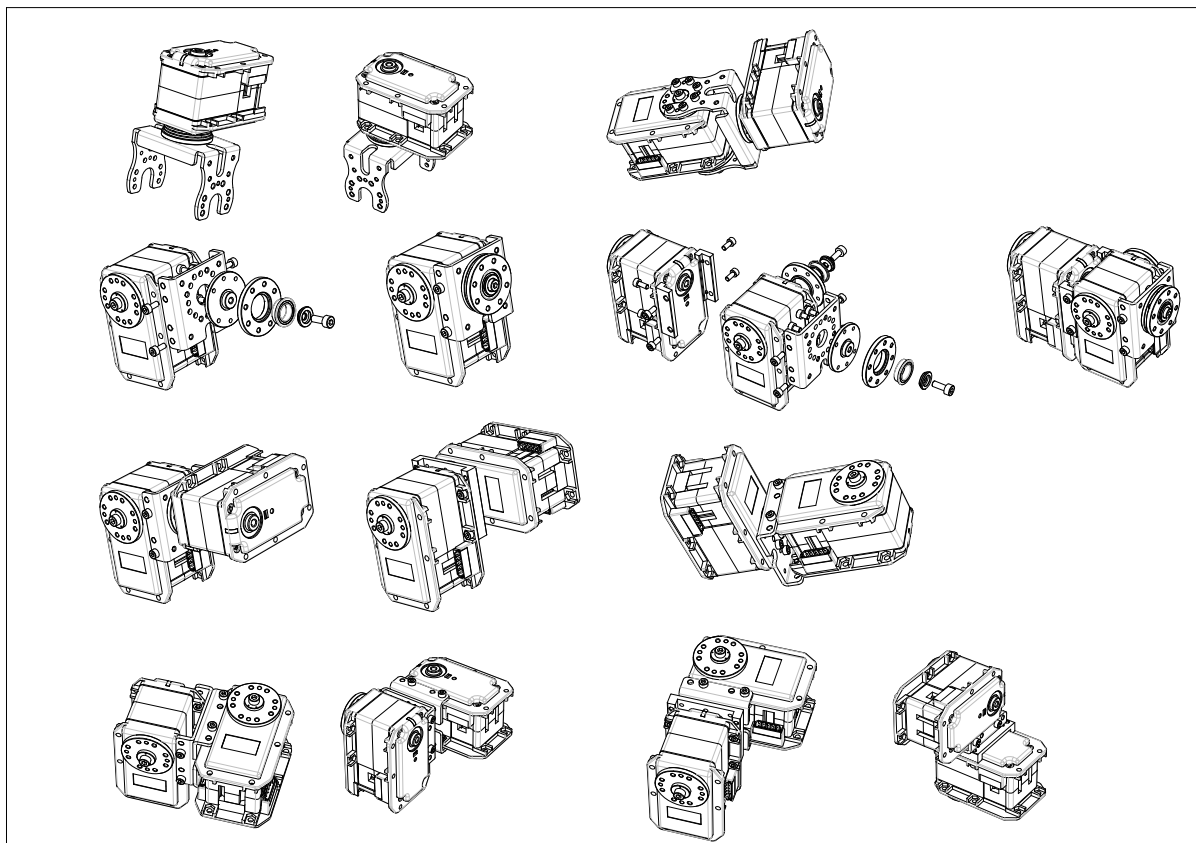

2-2. Assembling Connector

Connector is assembled in the following order.

1) Stripping



Peel the coating of cable to the extent of 5mm approx.

2) Inserting



Put the cable on the terminal like the left picture.

3) Forming



Press the cable and terminal by using Wire Former.

4) Formed Wire



Combine the terminal to the cable tightly like the left picture. Solder the terminal and cable after Forming to get the more solid combination.

5) Assembling

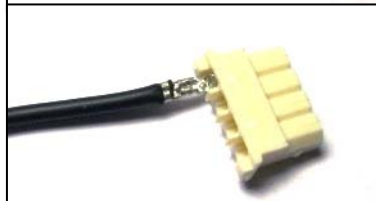

Insert the terminal into 4P Molex connector.

6) Complete



When inserting the terminal, be careful with the direction of the Molex connector.

Terminals should be inserted in the same way as the left picture

2-3. Wiring

Pin Assignment

The pin assignment of a connector is as shown below. RX-10 can be run by linking with any one of two 4P connectors of RX-10 since they are connected Pin2Pin internally.

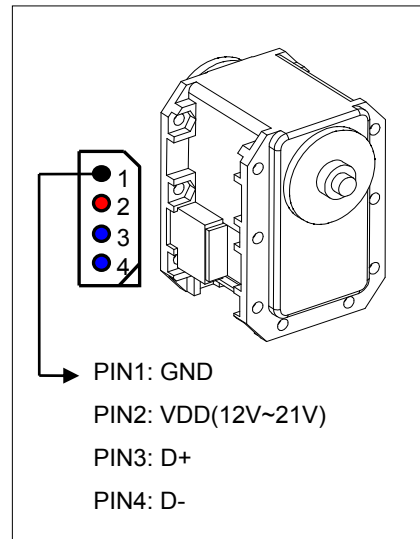
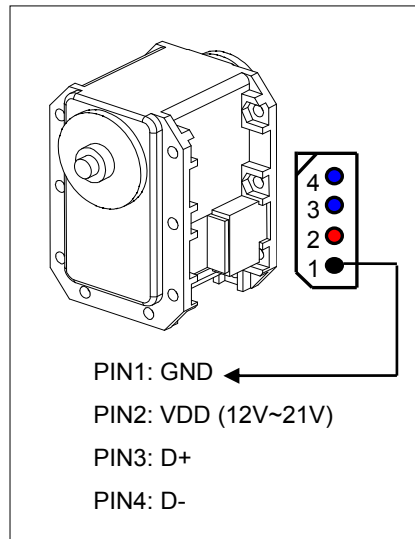

Wiring

Wiring should be done Pin2Pin as shown below. By connecting as such, several RX-10s can be controlled on a BUS.

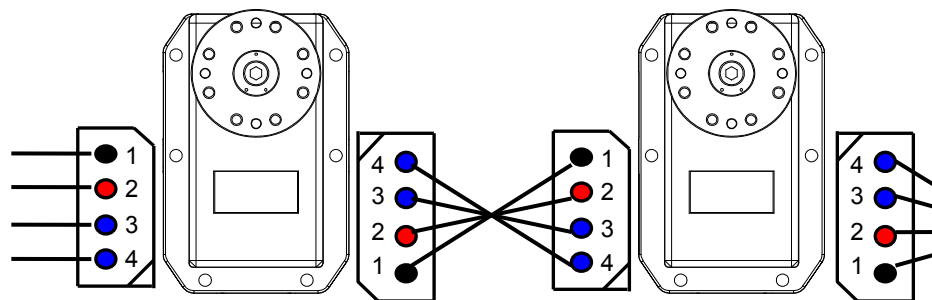



Please pay special attention to avoid incorrect pin assignments in wiring. Otherwise, RX-10 may be damaged.

2-4. Connection of Main Controller

Main Controller RX-10 uses the Multi-Drop Link method which connects several RX-10s to a Node by using Half Duplex UART. Thus, a Main Controller to run RX-10 must support RS485 UART. You can also design and use Main Controller by yourself.

(Refer to the website www.robotis.com)

Connection with PC If you want to control RX-10 with PC, you may control it via the Dynamixel-only controller or using the USB2Dynamixel. For further information, refer to the Dynamixel-only controller manual or the USB2Dynamixel manual.

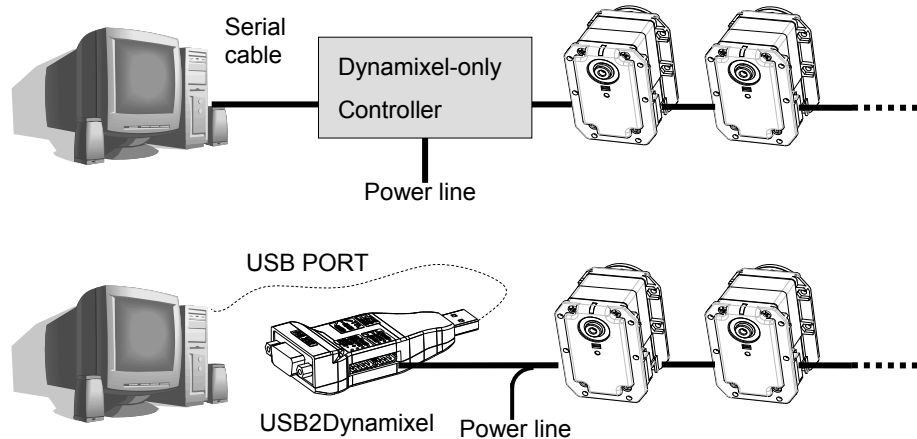

Connection with UART To control RX-10 with a personally made Main Controller, the signal of Main Controller UART should be converted into RS485 type signal. The following is a recommended circuit diagram.

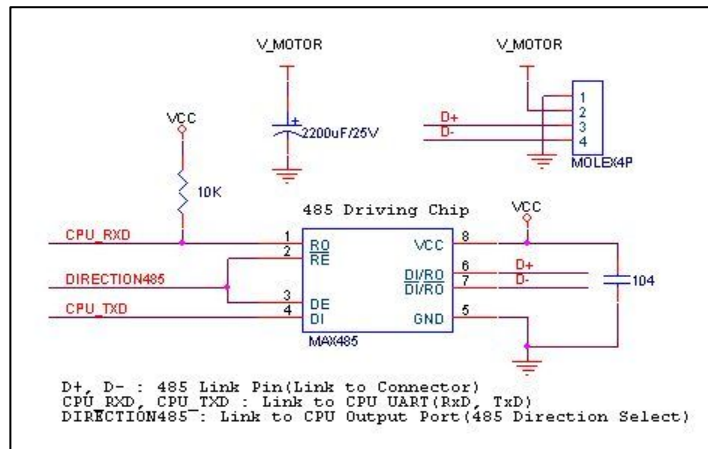

The power of RX-10 is supplied via Pin1(-), Pin2(+).

(The above circuit is built into Dynamixel-only controller.)

In the above circuit diagram, the direction of data signal of TxD and RxD in the TTL Level is determined according to the level of DIRECTION 485 as follows:

In case of DIRECTION485 Level = High: The signal of TxD is output to D+ and D-.

In case of DIRECTION485 Level = Low: The signal of D+ and D- is output to RxD.

Confirmation of Connection

The LED of RX-10 flickers once if the power is supplied to RX-10 properly via wiring.

Checking

If the above steps are not performed successfully, recheck the pin assignment of the connector. If the pin assignment is right, check the allowable voltage and current of the power supply.

 Note	Please check the current consumption when applying the power for the first time. The current consumption of RX-10 in the standby state is 50mA or less.
---------------------------------------------------------------------------------------------	---------------------------------------------------------------------------------------------------------------------------------------------------------

3. Communication with RX-10

1. Overview of Communication
2. Instruction Packet
3. Status Packet
4. Control Table
5. How to Use Packet

3-1. Overview of Communication

To control RX-10, communication should be established according to the protocol of RX-10. RX-10 is driven by receiving binary data. Examples of programs for the transmission of this kind of data are described in detail in the User's Manual of the Dynamixel-only controller or the USB2Dynamixel.

Thus, this manual describes only the method and protocol of communication used in RX-10 on the assumption that Main Controller can transfer binary data.

Packet Main Controller and RX-10 communicate each other by sending and receiving data called Packet. Packet has two kinds: Instruction Packet, which Main Controller sends to control RX-10, and Status Packet, which RX-10 responses to Main Controller.

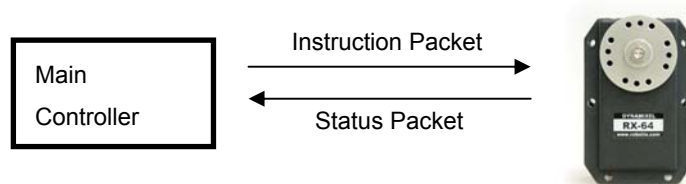

Role of ID ID is a specific number for distinction of each RX-10 when several RX-10s are linked to one bus. By giving IDs to Instruction and Status Packets, Main Controller can control only the RX-10 that you want to control

Protocol RX-10 does the Asynchronous Serial Communication with 8 bit, 1 Stop bit, and None Parity.

 Caution	If RX-10 with the same ID is connected, packet will collide and network problem will occur. Thus, set ID as such that there is no RX-10 with the same ID.
------------------------------------------------------------------------------------------------	-----------------------------------------------------------------------------------------------------------------------------------------------------------

 Note	ID of RX-10 is changeable. For this change, please refer to 'Changing IDs of Ex.2 and Ex.7'. The factory default setting ID is 1.
---------------------------------------------------------------------------------------------	--------------------------------------------------------------------------------------------------------------------------------------

3-2. Instruction Packet

Instruction Packet is command data that Main Controller sends to RX-10. The structure of Instruction Packet is as follows:



The meaning of each byte composing packet is as follows:

0xFF 0xFF

This signal notifies the beginning of the packet

ID

It is the ID of RX-10 which will receive Instruction Packet. It can use 254 IDs from 0 to 253 (0X00~0XFD).

Note

Broadcasting ID : ID = 254 (0XFE)
If Broadcast ID is used, all linked RX-10s execute command of Instruction Packet, and Status Packet is not returned.

LENGTH

It is the length of the packet. The length is calculated as “the number of Parameters (N) + 2”.

INSTRUCTION

This command gives an instruction to RX-10 and has the following types.

Value	Name	Function	No. of Parameters
0x01	PING	No execution. It is used when controller is ready to receive Status Packet	0
0x02	READ DATA	This command reads data from RX-64	2
0x03	WRITE DATA	This command writes data to RX-64	2 or more
0x04	REG WRITE	It is similar to WRTE_DATA, but it remains in the standby state without being executed until the ACTION command arrives.	2 or more
0x05	ACTION	This command initiates motions registered with REG WRITE	0
0x06	RESET	This command restores the state of RX-64 to the factory default setting.	0
0x83	SYNC WRITE	This command is used to control several RX-64s simultaneously at a time.	4 or more

PARAMETER0...N

Parameter is used when Instruction requires ancillary data. For the usage of parameters, refer to “3-5 How to Use Packet”

CHECK SUM

It is used to check if packet is damaged during communication. Check Sum is calculated according to the following formula.

$$\text{Check Sum} = \sim (\text{ID} + \text{Length} + \text{Instruction} + \text{Parameter1} + \dots \text{Parameter N})$$

Where, “~” is the Not Bit operator.

When the calculation result of the parenthesis in the above formula is larger than 255 (0xFF), use only lower bytes.

For example, when you want to use Instruction Packet like the below

ID=1 (0x01), Length= 5 (0x05), Instruction= 3 (0x03),
 Parameter1= 12 (0x0C), Parameter2= 100 (0x64), Parameter3= 170 (0xAA)

$$\begin{aligned} \text{Check Sum} &= \sim (\text{ID} + \text{Length} + \text{Instruction} + \text{Parameter1} + \dots \text{Parameter 3}) \\ &= \sim [0x01 + 0x05 + 0x03 + 0x0C + 0x64 + 0xAA] \\ &= \sim [0x123] \quad // \text{ Only the lower byte } 0x23 \text{ executes the Not operation.} \\ &= 0xDD \end{aligned}$$

Thus, Instruction Packet should be 0x01, 0x05, 0x03, 0x0C, 0x64, 0xAA, 0xDD.

3-3. Status Packet (Return Packet)

RX-10 executes command received from the Main controller and returns the result to the Main Controller. The returned data is called Status Packet. The structure of Status Packet is as follows:

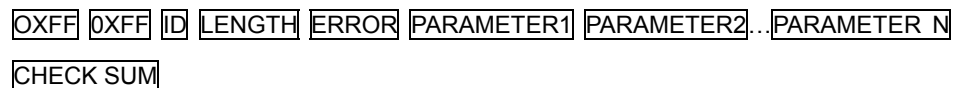

Each byte composing the packet means as below.

[0xFF] [0xFF]

This signal notifies the beginning of the packet.

[ID]

It is the ID of RX-10 which transfers Status Packet.

[LENGTH]

It is the length of Status Packet, the value of which is "the number of Parameters (N) + 2".

[ERROR]

It displays the error status occurred during the operatio of RX-10. The meaning of each bit is described in the below table.

Bit	Name	Contents
Bit 7	0	-
Bit 6	Instruction Error	In case of sending an undefined instruction or delivering the action command without the reg_write command, it is set as 1.
Bit 5	Overload Error	When the curren load cannot be controlled by the set Torque, it is set as 1.
Bit 4	Checksum Error	When the Checksum of the transmitted Instruction Packet is incorrect, it is set as 1.
Bit 3	Range Error	When a command is out of the range for use, it is set as 1.
Bit 2	Overheating Error	When internal temperature of Dynamixel is out of the range of operating temperature set in the Control table, it is set as 1.
Bit 1	Angle Limit Error	When Goal Position is written out of the range from CW Angle Limit to CCW Angle Limit , it is set as 1.
Bit 0	Input Voltage Error	When the applied voltage is out of the range of operating voltage set in the Control table, it is as 1.

For example, when Status Packet is returned as below

0xFF 0xFF 0x01 0x02 0x24 0xD8

It means that the error of 0x24 occurs from RX-10 whose ID is 01. Since 0x24 is 00100100 as binary, Bit5 and Bit2 become 1. In other words, Overload and Overheating Errors have occurred.

PARAMETER0...N

It returns data except **ERROR**. For the usage of parameters, refer to "3-5 How to Use Packet".

CHECK SUM

It is used to check if packet is damaged during communication. The below formula defines Check Sum. This formula is constructed in the same way as the Check Sum of Instruction Packet.

Check Sum = ~ (ID + Length + Error + Parameter1 + ... Parameter N)

3-4. Control Table

Control Table consists of data regarding the current status and operation, which exists inside of RX-10.

The user can control RX-10 by changing data of Control Table via Instruction Packet.

	Address (hexadecimal)	Name	Description	Access	Initial Value (Hexadecimal)
EEPROM Area	0 (0X00)	Model Number(L)	Lowest byte of model number	R	10 (0X0A)
	1 (0X01)	Model Number(H)	Highest byte of model number	R	0 (0X00)
	2 (0X02)	Version of Firmware	Information on the version of firmware	R	-
	3 (0X03)	ID	ID of Dynamixel	RW	1 (0X01)
	4 (0X04)	Baud Rate	Baud Rate of Dynamixel	RW	34 (0X22)
	5 (0X05)	Return Delay Time	Return Delay Time	RW	250 (0XFA)
	6 (0X06)	CW Angle Limit(L)	Lowest byte of clockwise Angle Limit	RW	0 (0X00)
	7 (0X07)	CW Angle Limit(H)	Highest byte of clockwise Angle Limit	RW	0 (0X00)
	8 (0X08)	CCW Angle Limit(L)	Lowest byte of counterclockwise Angle Limit	RW	255 (0XFF)
	9 (0X09)	CCW Angle Limit(H)	Highest byte of counterclockwise Angle Limit	RW	3 (0X03)
	11 (0X0B)	the Highest Limit Temperature	Internal Limit Temperature	RW	80 (0X50)
	12 (0X0C)	the Lowest Limit Voltage	Lowest Limit Voltage	RW	60 (0X3C)
	13 (0X0D)	the Highest Limit Voltage	Highest Limit Voltage	RW	240 (0XF0)
	14 (0X0E)	Max Torque(L)	Lowest byte of Max. Torque	RW	255 (0XFF)
	15 (0X0F)	Max Torque(H)	Highest byte of Max. Torque	RW	3 (0X03)
	16 (0X10)	Status Return Level	Status Return Level	RW	2 (0X02)
	17 (0X11)	Alarm LED	LED for Alarm	RW	36 (0X24)
	18 (0X12)	Alarm Shutdown	Shutdown for Alarm	RW	36 (0X24)
RAM Area	24 (0X18)	Torque Enable	Torque On/Off	RW	0 (0X00)
	25 (0X19)	LED	LED On/Off	RW	0 (0X00)
	26 (0X1A)	CW Compliance Margin	CW Compliance margin	RW	0 (0X00)
	27 (0X1B)	CCW Compliance Margin	CCW Compliance margin	RW	0 (0X00)
	28 (0X1C)	CW Compliance Slope	CW Compliance slope	RW	32 (0X20)
	29 (0X1D)	CCW Compliance Slope	CCW Compliance slope	RW	32 (0X20)
	30 (0X1E)	Goal Position(L)	Lowest byte of Goal Position	RW	-
	31 (0X1F)	Goal Position(H)	Highest byte of Goal Position	RW	-
	32 (0X20)	Moving Speed(L)	Lowest byte of Moving Speed	RW	-
	33 (0X21)	Moving Speed(H)	Highest byte of Moving Speed	RW	-
	34 (0X22)	Torque Limit(L)	Lowest byte of Torque Limit	RW	ADD14
	35 (0X23)	Torque Limit(H)	Highest byte of Torque Limit	RW	ADD15
	36 (0X24)	Present Position(L)	Lowest byte of Current Position	R	-
	37 (0X25)	Present Position(H)	Highest byte of Current Position	R	-
	38 (0X26)	Present Speed(L)	Lowest byte of Current Speed	R	-
	39 (0X27)	Present Speed(H)	Highest byte of Current Speed	R	-
	40 (0X28)	Present Load(L)	Lowest byte of Current Load	R	-
	41 (0X29)	Present Load(H)	Highest byte of Current Load	R	-
	42 (0X2A)	Present Voltage	Current Voltage	R	-
	43 (0X2B)	Present Temperature	Current Temperature	R	-
	44 (0X2C)	Registered Instruction	Means if Instruction is registered	RW	0 (0X00)
	46 (0X2E)	Moving	Means if there is any movement	R	0 (0X00)
	47 (0X2F)	Lock	Locking EEPROM	RW	0 (0X00)
	48 (0X30)	Punch(L)	Lowest byte of Punch	RW	32 (0X20)
	49 (0X31)	Punch(H)	Highest byte of Punch	RW	0 (0X00)

- RAM and EEPROM** Data in RAM area is reset to the initial value whenever the power is turned on while data in EEPROM area is kept once the value is set even if the power is turned off.
- Address** It represents the location of data. To read data from or write data to RX-10, the user should assign an address where the data locates to Packet.
- Access** RX-10 has two kinds of data: Read-only data, which is mainly used for sensing, and Read-and-Write data, which is used for driving.
- Initial Value** In case of data in the EEPROM Area, the initial values on the right side of the above Control Table are the factory default settings. In case of data in the RAM Area, the initial values on the right side of the above Control Table are the ones when the power is turned on.
- Highest/Lowest Byte** In the Control table, some data share the same name, but they are attached with (L) or (H) at the end of each name to distinguish the address. This data requires 16bit, but it is divided into 8bit each for the addresses (low) and (high). These two addresses should be written with one Instruction Packet at the same time.

3-4-1 Control Table Items (EEPROM Area)

Model Number. Address 0, 1 (0x00, 0x01) In case of RX-10, the data value is 28 (0X001C).

Firmware Version Address 2 (0x02) It represents the firmware version.

ID Address 3 (0x03) It is a unique number to identify RX-10. 0 to 253 (0xFD) can be used for it and the factory default setting is 1.

Baud Rate Address 4 (0x04) It represents the communication speed. 0 to 254 (0xFE) can be used for it. This speed is calculated by using the below formula.

$$\text{Speed (BPS)} = 2000000 / (\text{Data} + 1)$$

Data value per Baud Rate

Data	Set BPS	Target BPS	Tolerance
1	1000000.0	1000000.0	0.000%
3	500000.0	500000.0	0.000%
4	400000.0	400000.0	0.000%
7	250000.0	250000.0	0.000%
9	200000.0	200000.0	0.000%
16	117647.1	115200.0	-2.124%
34	57142.9	57600.0	0.794%
103	19230.8	19200.0	-0.160%
207	9615.4	9600.0	-0.160%



If the tolerance of Baud Rate is less than 3 %, there is no problem with communication. The initial value of Baud rate is 34 (0x22) (i.e., 57600bps).

Note

Return Delay Time Address 5 (0x05) It is the delay time that takes from the transmission of Instruction Packet until the return of Status Packet. 0 to 254 (0xFE) can be used, and the delay time per data value 1 is 2 usec. That is to say, if the data value is 10, 20 usec is delayed. The initial value is 250 (0xFA) (i.e., 0.5 msec).

Operating Angle Limit Address 6, 7, 8, 9 (0x06,0x07,0x08,0x09) It represents the allowed range of movement. The range for use is 0 to 1023 (0x3FF). Data 0 denotes 0° and Data 1023 (0x3FF) 300°. Thus, the angle per data value 1 is about 0.3°.

Highest Limit Temperature Address 11 (0x0B) It is the highest limit of operating temperature. The range for use is 10 to 99 (0x10~0x63). If the internal temperature of RX-10 exceeds this range, Over Heating Error Bit (Bit2) of Status Packet is returned as '1' and Alarm is triggered as set in the addresses 17 and 18. The value is equal to the actual Celsius temperature. In other words, the initial value Data 80 (0x50) is 80°C.

 Caution	Do not set The Highest Limit Temperature of RX-10 above the initial value of 80°C. If RX-10 is used at the temperature of 80°C or higher, it may be damaged
----------------------------------------------------------------------------------------------	-------------------------------------------------------------------------------------------------------------------------------------------------------------

Lowest / Highest Limit Voltage Address 12, 13 (0x0C, 0x0D) It is the operation range of voltage. 50 to 250 (0x32 ~ 0x96) can be used. If Present Voltage (Address42) is out of the range, Voltage Range Error Bit (Bit0) of Status Packet is returned as '1' and Alarm is triggered as set in the addresses 17 and 18. Data value is 10 times larger than actual voltage. For example, the Lowest Limit Voltage Data of 80 means that the Lowest Limit Voltage is set as 8V.

Max Torque Address 14, 15 (0x0E, 0x0F) It is the torque value of maximum output. 0 to 1023 (0x3FF) can be used. The value set to '0' means the Free Run state without torque. Max Torque is allocated to EEPROM (Addresses 14 and 15) and RAM (Addresses 34 and 35). When the power is turned on, EEPROM value is copied to RAM. In actual operation, the maximum torque is restrained by Torque Limit (Addresses 34 and 35) located in RAM. Data value represents the ratio of Torque output under the currently applied voltage. In other words, Data 1023 (0x3FF) means that RX-10 will use 100% of the maximum torque it can produce while Data 512 (0x200) means that RX-10 will use 50% of the maximum torque. For stopping torque value according to the state of voltage of RX-10, refer to "1-3 Specifications of RX-10".

Status Return Level Address 16 (0X10) It decides how to return Status Packet. There are three ways like the below table.

Address16	Return of Status Packet
0	No return against all instructions
1	Retrun only for the READ_DATA command
2	Return for all Instructions



When Instruction Packet is Broadcast ID, Status Packet is not returned regardless of Status Return Level.

Note

When Instruction Packet is Ping, Status Packet is returned regardless of Status Return Level.

Alarm LED Address 17 (0X11) It shows an error status occurred during operation through LED. Alarm LED is allocated with a bit according to each error content like the below table and it flickers when the bit is set as 1 and the corresponding error occurs.

The function of each bit runs the logic of 'OR'. That is to say, LED flickers even if 0X05 (binary 00000101) is set and Input Voltage Error or Overheating Error occurs. LED stops flickering in two seconds when error occurs and is recovered to the normal state.

Bit	Name	Contents
Bit 7	0	-
Bit 6	Instruction Error	When undefined Instruction is transmitted or the Action command is delivered without the reg_write command
Bit 5	Overload Error	When the current load cannot be controlled with the set maximum torque
Bit 4	Checksum Error	When the Checksum of the transmitted Instruction Packet is invalid
Bit 3	Range Error	When the command is given beyond the range of usage
Bit 2	Overheating Error	When the internal temperature is out of the range of operating temperature set in the Control Table
Bit 1	Angle Limit Error	When Goal Position is written with the value that is not between CW Angle Limit and CCW Angle Limit
Bit 0	Input Voltage Error	When the applied voltage is out of the range of operating voltage set in the Control Table

Alarm Shut down Address 18 (0X12) It turns Torque off when an error occurs during operation. It also allocates each error content in the same way as Alarm LED. It turns Torque off when the Data bit is set as “1” and the applicable error occurs.

The function of each Bit runs the logic of ‘OR’ in the same way as Alarm LED. However, unlike Alarm LED, the Torque OFF state is maintained even if an error occurs and is recovered to the normal state. To get out of the Shut down state, you should reset a value you want into the Torque Limit (Addresses 34 and 35).

3-4-2 Control Table Items (RAM Area)

Torque Enable Address 24 (0x18) When the power is supplied to RX-10 for the first time, RX-10 is in the Free Run state in which case there is no torque generated. When Torque Enable is set as "1", Torque is generated.

LED Address 25 (0x19) When it is set as "1", LED is turned on; when it is set as "0", LED is turned off.

Compliance Margin & Slope Address 26~29 (0x1A~0x1D) Compliance is to set the pattern of output torque. Making well use of it will result in shock absorption, smooth motion, etc. The length of A, B, C, and D in the below graph (Position vs. Torque curve) is the value of Compliance. Compliance Margin is available from 0 to 254 (0xFE) while Compliance Slope is valid from 1 to 254 (0xFE).

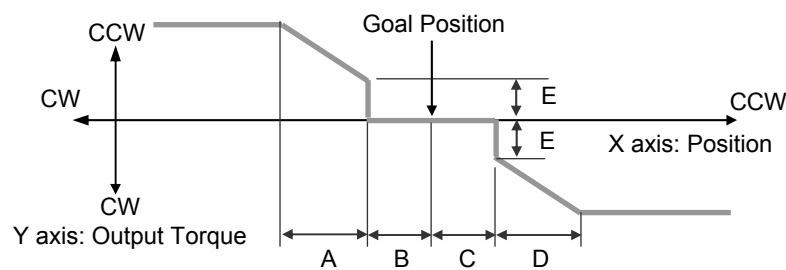

- A : CW Compliance Slope (Address 28)
- B : CW Compliance Margin (Address 26)
- C : CCW Compliance Margin (Address 27)
- D : CCW Compliance Slope (Address 29)
- E : Punch (Address 48, 49)

B and C (Compliance Margin) are the areas where output torque is 0.
 A and D (Compliance Slope) are the areas where output torque is reduced when they are getting close to Goal Position. The wider these areas are, the smoother the motion is.

Compliance Slope can be defined as seven levels in total as shown in the below table. It recognizes the data values 1 to 5 as 4, valid position value, while the data values 6 to 11 as 8. Thus, it is convenient to set up the data of Compliance Slope as the valid position value in the below table. The initial value is 32 (0x20) in the 4th level.

Level	Data Value	Valid Position Value
1	1 (0x00) ~ 5 (0x05)	4 (0x04)
2	6 (0x06) ~ 11 (0x0B)	8 (0x08)
3	12 (0x0C) ~ 23 (0x17)	16 (0x10)
4	24 (0x18) ~ 47 (0x2F)	32 (0x20)
5	48 (0x30) ~ 95 (0x5F)	64 (0x40)
6	96 (0x60) ~191 (0xBF)	128 (0x80)
7	192 (0xC0)~254 (0xFE)	254 (0xFE)

For example, if the current position is set as 200 (0x0C8), Goal Position is set as 512 (0x200), and Compliance is set as below,

Area	A	B	C	D	E
Data	16	5	5	16	10

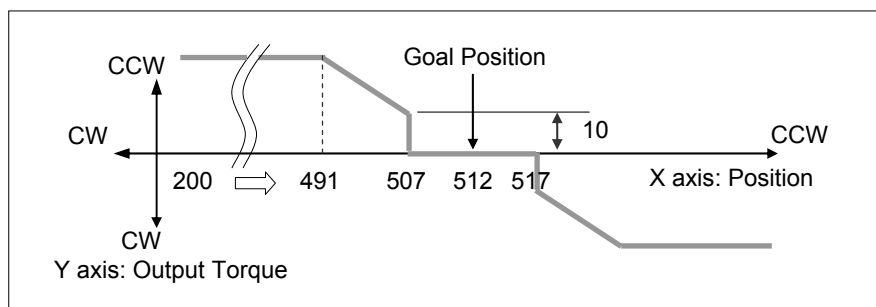

From the current position 200 to 491 ($512-16-5=491$), movement is made with appropriate torque to reach the set speed; from 491 to 507 ($512-5=507$), torque is continuously reduced to the Punch value; from 507 through 517 ($512+5=517$), no torque is generated.

Goal Position

Address 30, 31 (0X1E, 0x1F) It is a position value of destination. 0 to 1023 (0x3FF) is available. Position values according to data values are as shown in the below picture. Goal Position should be used within the range of CW Angle Limit ≤ Goal Position ≤ CCW Angle Limit; when it is out of the range, Angle Limit Error occurs.

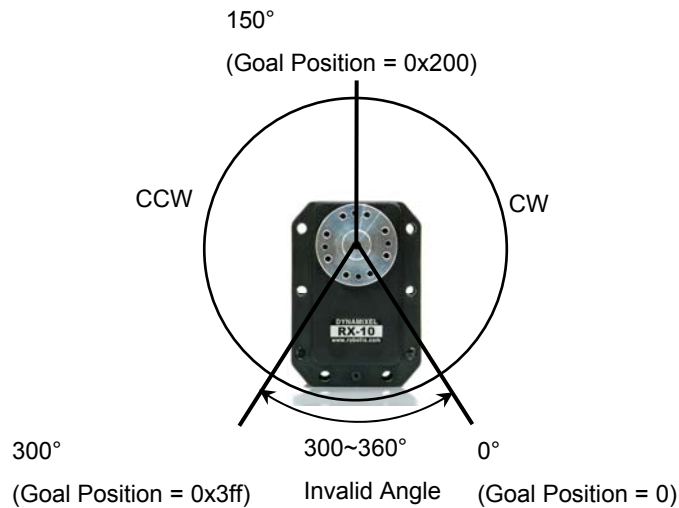

Moving Speed

Address 32, 33 (0x20, 0x21) It is a moving speed to Goal Position. 0 to 1023 (0X3FF) can be set for the speed.

Present Speed

Address 38, 39 (0x26, 0x27) It is the current moving speed of RX-10. 0 to 1023 (0X3FF) can be measured.

Moving Speed and Present Speed can be converted into RPM when data value is multiplied by 0.111. For example, Data 1023 is 114RPM (1023x0.111=113.6). But, the maximum speed of RX-10 is less than 114RPM. Nevertheless, the range of speed data value is set up to 114 RPM since RX-10 can move faster than the maximum speed by outside factors.

The maximum speed of RX-10 is in proportion to the size of supplied voltage. In other words, the higher voltage it is supplied with, the wider range of speed it can control. For example, when RX-10 is supplied with 12V, it can reach to the speed of 84.0RPM and control the speed with 0 to 84.0 RPM. However, when it is supplied with 10V, the

maximum speed is reduced to 69.9RPM so that the speed with 0 to 69.9 RPM can be controlled. The relationship between data value and speed is as shown in the below picture.

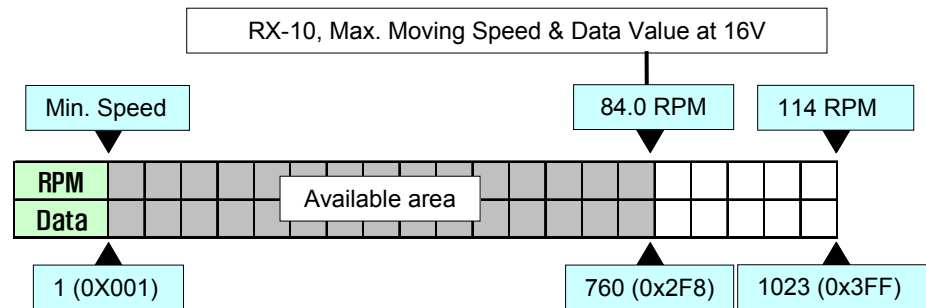

 **Note** When Moving Speed is set as 1 (0X001), movement is made at the minimum speed. When Moving Speed is set as 0 (0x000), movement is made at the maximum speed which can be reached under the applied voltage. In other words, setting as 0 means that no speed control will be done.

Torque Limit

Address 34, 35. (0x22, 0x23) It sets the maximum output Torque. 0 to 1023 (0x3FF) is available. Torque related data is allocated in EEPROM (Addresses 14 and 15) and RAM (Addresses 34 and 35). And when the power is on, the EEPROM value is copied to RAM. Torque is restricted by the Torque Limit value located in RAM (Addresses 34 and 35) in driving. Data value represents the ratio of Torque that can be output under the currently applied voltage as described in Max Torque

Present Position

Address 36, 37 (0x24,0x25) It is the current position of RX-10. The unit is the same as that of Goal Position.

Present Load

Address 40, 41 (0x28,0x29) It is the size of the load currently being driven by RX-10. The meaning of data per each bit in the Present Load is as below.

BIT	15~11	10	9	8	7	6	5	4	3	2	1	0
Value	0	Load Direction	Data (Load Ratio)									

Load Direction = 0 : CCW Load, Load Direction = 1: CW Load

Data value indicates the ratio of Torque as described in Max Torque. For example, data value is 1023 (0X3FF) when the maximum torque is generated but the load is too big for RX-10 to move, so that RX-10 ends up in the holding state.

Present Voltage Address 42 (0x2A) It is the size of the current voltage supplied. This value is 10 times larger than the actual voltage. For example, when 10V is supplied, the data value is 100 (0x64).

Present Temperature Address 43 (0x2B) It is the internal temperature of RX-10 in Celsius. Data value is identical to the actual temperature in Celsius. For example, if the data value is 85 (0x55), the current internal temperature is 85°C.

Registered Instruction Address 44 (0x2C) It is set as “1” when a command is registered by the REG_WRITE command of Instruction Packet. Then, it changes into “0” after executing a registered command by the Action command.

Moving Address 46 (0x2E) It is set as “1” while movement is being made with Goal Position set; it changes into “0” when Goal Position is reached.

Lock Address 47 (0x2F) Setting it as “1” leads to the lock state and only the values from Address 24 (0X18) to Address 35 (0x23) are writable. Once locked, it is impossible to unlock unless the power is off.

Punch Address 48, 49 (0x30,0x31) It is the limit value of torque being reduced when the output torque is decreased in the Compliance Slope area. In other words, it is the minimum torque. The initial value is 32 (0x20) and can be extended up to 1023 (0x3FF). (Refer to Compliance margin & Slope)

3-4-3 Endless Turn

Endless Turn can be materialized when CW Angle Limit (Address 6,7) and CCW Angle Limit (Address8,9) are set as “0”. It can be usefully applied to move wheels.

Endless Turn has no speed control function. Enter a desired torque value into Moving Speed (Addresses 32 and 33 (0X20 and 0X21)). The meaning of Moving Speed Address is as shown in the below picture.

Data value in the table represents the ratio of output torque. For example, Data 1023 (0x3FF) means that 100% of torque should be generated in the current voltage state while data 512 (0x200) means that 50% of torque should be generated.

BIT	15~11	10	9	8	7	6	5	4	3	2	1	0
Value	0	Turn Direction	Data (Torque Ratio)									

Turn Direction = 0 : CCW Direction Turn, Turn Direction = 1: CW Direction Turn

3-5. How to Use Packet

To operate RX-10, Instruction Packet, which is binary type data, should be sent to RX-10 from Main Controller. Instruction Packet has seven kinds of commands. (Refer to “3-2 Instruction Packet”)

In addition, RX-10 receives Instruction Packet to performs a command and returns the result as Status Packet to Main Controller. This section describes examples of the usage of each command of Instruction Packet.

3-5-1 READ DATA

Function	This command is to read data in the Control Table inside of RX-10.
Length	0X04
Instruction	0X02
Parameter1	Start Address of data to be read
Parameter2	Length of Data to be read

Example 1 Reads the current internal temperature of RX-10 whose ID is 1.

Reads 1 byte from the value of Address 43 (0x2B) in the Control Table.

Instruction Packet : 0XFF 0XFF 0X01 0X04 0X02 0X2B 0X01 0XCC

ID	LENGTH	INSTRUCTION	PARAMETERS
----	--------	-------------	------------

↑ ↑ ↑ ↙ ↘

CHECKSUM

Status Packet returned is as follows:

Status Packet : 0XFF 0XFF 0X01 0X03 0X00 0X20 0XDB

ID	LENGTH	ERROR	PARAMETER1	CHECKSUM
----	--------	-------	------------	----------

↑ ↑ ↑ ↙ ↘

Data value read is 0x20 (i.e., 32 in decimal). Thus, the current internal temperature of

3-5-2 WRITE DATA

Function	This command is to write data to the Control Table inside of RX-10.
Length	N+3 (if the number of writing data is N)
Instruction	0X03
Parameter1	Start address to write data
Parameter2	First data to write
Parameter3	Second data to write
Parameter N+1	Nth Data to write

Example 2	Sets the ID of RX-10 as "1".
------------------	------------------------------

Writes 1 to the Address 3 in the Control Table.

Sends ID as Broadcasting ID(0xFE).

Instruction Packet : 0XFF 0XFF 0XFE 0X04 0X03 0X03 0X01 0XF6`

Status Packet is not returned since Broadcast ID (0xFE) is transmitted.

3-5-3 REG WRITE

Function	The REG_WRITE command is similar to the WRITE_DATA command in terms of function, but differs in terms of the timing that a command is executed. When Instruction Packet arrives, it is saved in Buffer and the Write operation remains in the standby state. At this moment, Registered Instruction (Address 44 (0x2C)) is set as “1”. Then, when Action Instruction Packet arrives, Registered Instruction changes into “0” and the registered Write command is finally executed.
Length	N+3 (if the number of Writing Data is N)
Instruction	0X04
Parameter1	Start Address to write Data
Parameter2	First data to write
Parameter N+1	Nth data to write

3-5-4 ACTION

Function	This command is to execute the Write action registered by REG_WRITE
Length	0X02
Instruction	0X05
Parameter	NONE

The Action command is useful when several RX-10s are moved with accuracy at the same time. When several running gears are controlled via communication, there is a little time difference in terms of enabling time between the first and the last running gear getting commands. RX-10 has resolved this problem by using Action Instruction.

 <div style="border: 1px solid black; padding: 2px; width: fit-content; margin: 0 auto;">Note</div>	<p>In case of transmitting the Action command to more than two RX-10s, Broadcast ID(0XFE) should be used, but Status Packet is not returned at this time.</p>
-------------------------------------------------------------------------------------------------------------------------------------------------------------------------------------------	---------------------------------------------------------------------------------------------------------------------------------------------------------------

3-5-5 PING

Function	This command does not instruct anything. It is only used when receiving Status Packet or confirming the existence of RX-10 with a specific ID.
Length	0X02
Instruction	0X01
Parameter	NONE

Example 3	Receives Status Packet of RX-10 whose ID is 1.
<p>Reads 1 byte from the value of Address 43 (0x2B) in the Control Table.</p> <p>Instruction Packet : 0XFF 0XFF 0X01 0X02 0X01 0XFB`</p> <div style="text-align: center; margin: 10px 0;"> </div> <p>Status Packet returned is as follows:</p> <p>Status Packet : 0XFF 0XFF 0X01 0X02 0X00 0XFC</p> <div style="text-align: center; margin: 10px 0;"> </div>	

 <div style="border: 1px solid black; padding: 2px; width: 30px; margin: 0 auto;">Note</div>	<p>Although Status Return Level (Address 16 (0X10)) is 0, it returns Status Packet all the time for Ping Instruction. But, it does not return Status Packet when Check Sum Error occurs in spite of using PING Instruction.</p>
-------------------------------------------------------------------------------------------------	---------------------------------------------------------------------------------------------------------------------------------------------------------------------------------------------------------------------------------

3-5-6 RESET

Function	This command is to reset the Control Table of RX-10 to the factory default setting.
Length	0X02
Instruction	0X06
Parameter	NONE

Example 4	Resets the Control Table of RX-10 whose ID is 0.
<p>Instruction Packet : 0XFF 0XFF 0X00 0X02 0X06 0XF7`</p> <div style="text-align: center; margin: 10px 0;"> </div> <p>Status Packet returned is as follows:</p> <p>Status Packet : 0XFF 0XFF 0X00 0X02 0X00 0XFD</p> <div style="text-align: center; margin: 10px 0;"> </div> <p>Please note that ID is changed into "1" after the execution of the RESET command.</p>	

 Caution	Please note that the value set by the user is removed when the RESET command is used.
-------------	---------------------------------------------------------------------------------------

3-5-7 SYNC WRITE

Function This command is used to control several RX-10s simultaneously with one Instruction Packet transmission. When this command is used, several commands are transmitted at once, so that the communication time is reduced when multiple RX-10s are controlled. However, the SYNC WRITE command can be used only if both of the address and length of the Control Table to write is identical. Besides, ID should be transmitted as Broadcasting ID. Make sure that the length of packet does not to exceed 143 bytes since the volume of receiving buffer of RX-10 is 143 bytes.

ID	0XFE	
Length	(L+1) X N + 4	(L: Data Length per RX-10, N: the number of RX-10s)
Instruction	0X83	
Parameter1	Start address to write Data	
Parameter2	Length of Data to write	
Parameter3	First ID of RX-10	} Data regarding the first RX-10
Parameter4	First data of the first RX-10	
Parameter5	Second data of the first RX-10	
...		
Parameter L+3	Lth Data of the first RX-10	} Data regarding the second RX-10
Parameter L+4	ID of the second RX-10	
Parameter L+5	First data of the second RX-10	
Parameter L+6	Second data of the second RX-10	
...		
Parameter 2L+4	Lth data of the second RX-10	

Example 5 Moves to the following position and speed for each RX-10.

RX-10 with ID 0 : Moves to the position of 0x010 at the speed of 0x150
 RX-10 with ID 1 : Moves to the position of 0x220 at the speed of 0x360
 RX-10 with ID 2: Moves to the position of 0x030 at the speed of 0x170
 RX-10 with ID 3: Moves to the position of 0x220 at the speed of 0x380

Instruction Packet : 0XFF 0XFF 0XFE 0X18 0X83 0X1E 0X04 0X00 0X10 0X00
 0X50 0X01 0X01 0X20 0X02 0X60 0X03 0X02 0X30 0X00
 0X70 0X01 0X03 0X20 0X02 0X80 0X03 0X12`

Status Packet is not returned since ID is transmitted as Broadcasting ID.

3-5-8 Other Examples

The following examples are supposed that ID is 1 and Baud rate is 57142 BPS.

Example 6	Reads the Model Number and Firmware Version.
Hint	Instruction = READ_DATA, Address = 0x00, Length = 0x03
Communication	Instruction Packet : FF FF 01 04 02 00 03 F5 Status Packet : FF FF 01 05 00 0A 00 08 7D
Status Packet Result	Model Number = 10 (0x0A) Firmware Version = 0x08

Example 7	Changes the ID of RX-10 from 1 to 0.
Hint	Instruction = WRITE_DATA, Address = 0x03, DATA = 0x00
Communication	Instruction Packet : FF FF 01 04 03 03 00 F4 Status Packet : FF FF 00 02 00 FC
Status Packet Result	NO ERROR

Example 8	Changes the Baud Rate to 1M bps.
Hint	Instruction = WRITE_DATA, Address = 0x04, DATA = 0x01
Communication	Instruction Packet : FF FF 01 04 03 04 01 F3 Status Packet : FF FF 01 02 00 FD
Status Packet Result	NO ERROR

Example 9	Resets Return Delay Time as 4usec.
Hint	Instruction = WRITE_DATA, Address = 0x05, DATA = 0x02
Communication	Instruction Packet : FF FF 01 04 03 05 02 F1 Status Packet : FF FF 01 02 00 FD
Status Packet Result	NO ERROR

 <div style="border: 1px solid black; padding: 2px; width: fit-content; margin: 0 auto;">Note</div>	<p>Return Delay Time Data 1 is equal to 2usec.</p> <p>It is recommended that Return Delay Time be set as the minimum value within the allowed range of Main Controller.</p>
-----------------------------------------------------------------------------------------------------------------------------------------------------------------------------------------	-----------------------------------------------------------------------------------------------------------------------------------------------------------------------------

Example 10	Restricts the movement angle from 0 to 150°.
Hint	<p>Since CCW Angle Limit 0x3FF means 300°, 150° corresponds to 0x200.</p> <p>Instruction = WRITE_DATA, Address = 0x08, DATA = 0x00, 0x02</p>
Communication	Instruction Packet : FF FF 01 05 03 08 00 02 EC Status Packet : FF FF 01 02 00 FD
Status Packet Result	NO ERROR

Example 11	Resets the highest limit of operating temperature as 80°.
Hint	Instruction = WRITE_DATA, Address = 0x0B, DATA = 0x50
Communication	Instruction Packet : FF FF 01 04 03 0B 50 9D Status Packet : FF FF 01 02 00 FD
Status Packet Result	NO ERROR

Example 12	Sets the operating voltage as 10 to 17V.
Hint	Data of 10V is 100 (0x64) while 17V is 170 (0xAA). Instruction = WRITE_DATA, Address = 0x0C, DATA = 0x64, 0xAA
Communication	Instruction Packet : FF FF 01 05 03 0C 64 AA DD Status Packet : FF FF 01 02 00 FD
Status Packet Result	NO ERROR

Example 13	Only generates 50% of the maximum torque.
Hint	Sets the value of MAX Torque located in the EEPROM area as 0x1FF, which is 50% of the maximum value 0x3FF. Instruction = WRITE_DATA, Address = 0x0E, DATA = 0xff, 0x01
Communication	Instruction Packet: FF FF 01 05 03 0E FF 01 E9 Status Packet : FF FF 01 02 00 FD
Status Packet Result	NO ERROR
The change of Max Torque can be checked by turning the power off and then on.	

Example 14	Do not return Status Packet all the time.
Hint	Instruction = WRITE_DATA, Address = 0x10, DATA = 0x00
Communication	Instruction Packet: FF FF 01 04 03 10 00 E8 Status Packet : FF FF 01 02 00 FD
Status Packet Result	NO ERROR
Status Packet is not returned from the next Instruction.	

Example 15	Sets the Alarm as such that LED flickers and shutdown (torque off) when the operating temperature is higher than the limit temperature.
Hint	<p>Since Overheating Error is Bit 2, set up Alarm value as 0x04. (0x04=00000100)</p> <p>Instruction = WRITE_DATA, Address = 0x11, DATA = 0x04, 0x04</p>
Communication	<p>Instruction Packet: FF FF 01 05 03 11 04 04 DE</p> <p>Status Packet : FF FF 01 02 00 FD</p>
Status Packet Result	NO ERROR

Example 16	Turns on the LED and enables Torque.
Hint	<p>Instruction = WRITE_DATA, Address = 0x18, DATA = 0x01, 0x01</p>
Communication	<p>Instruction Packet: FF FF 01 05 03 18 01 01 DD</p> <p>Status Packet : FF FF 01 02 00 FD</p>
Status Packet Result	NO ERROR
	You can check the Torque Enable state by touching the axis of Dynamixel you're your hand.

Example 17	Locates at the Position 180° with the speed of 57RPM.
Hint	<p>Sets Goal Position (Address 30 (0x1E))= 511 (0x1FF) and Moving Speed (Address 0x20)= 512 (0x200).</p> <p>Instruction = WRITE_DATA, Address = 0x1E, DATA = 0x00, 0x02, 0x00, 0x02</p>
Communication	<p>Instruction Packet: FF FF 01 07 03 1E 00 02 00 02 D3</p> <p>Status Packet : FF FF 01 02 00 FD</p>
Status Packet Result	NO ERROR

Example 18 Sets Compliance Margin=1 and Compliance Slope=0x40.

Hint The suggested condition can be depicted in a graph as below.

A: CCW Compliance Slope (Address 29 (0x1D)) = 0x40 (about 18.8°)
 B: CCW Compliance Margin (Address 27 (0x1B)) = 0x01 (about 0.3°)
 C: CW Compliance Margin (Address 26 (0x1A)) = 0x01 (about 0.3°)
 D: CW Compliance Slope (Address 28 (0x1C)) = 0x40 (about 18.8°)

Instruction = WRITE_DATA, Address = 0x1A,
 DATA = 0x01, 0x01, 0x40, 0x40

Communication Instruction Packet: FF FF 01 07 03 1A 01 01 40 40 59
 Status Packet : FF FF 01 02 00 FD

Status Packet Result NO ERROR

Example 19 Sets the minimum output Torque (Punch) as 0x40.

Hint Instruction = WRITE_DATA, Address = 0x30,
 DATA = 0x40, 0x00

Communication Instruction Packet : FF FF 01 05 03 30 40 00 87
 Status Packet : FF FF 01 02 00 FD

Status Packet Result NO ERROR

Example 20	Locates RX-10 with ID 0 at Position 0° and RX-10 with ID 1 at Position 300°. Start only two RX-10s at the same point.
Hint	<p>When the WRITE_DATA command is used, two RX-10s cannot be started at the same point.</p> <p>Thus, REG_WRITE and ACTION are used.</p> <p>ID=0, Instruction = REG_WRITE, Address = 0x1E, DATA = 0x00, 0x00</p> <p>ID=1, Instruction = REG_WRITE, Address = 0x1E, DATA = 0xff, 0x03</p> <p>ID=0xfe(Broadcasting ID), Instruction = ACTION,</p>
Communication	<p>Instruction Packet: FF FF 00 05 04 1E 00 00 D8</p> <p>Status Packet : FF FF 00 02 00 FD</p> <p>Instruction Packet: FF FF 01 05 04 1E FF 03 D5</p> <p>Status Packet : FF FF 01 02 00 FC</p> <p>Instruction Packet: FF FF FE 02 05 FA (LEN:006)</p> <p>Status Packet //No return packet</p>
Status Packet Result	NO ERROR

Example 21	Unable to change values except Address 24 to Address 35.
Hint	<p>Set Lock (Address 47 (0x2F)) as 1.</p> <p>Instruction = WRITE_DATA, Address = 0x2F, DATA = 0x01</p>
Communication	<p>Instruction Packet : FF FF 01 04 03 2F 01 C8</p> <p>Status Packet : FF FF 01 02 00 FD</p>
Status Packet Result	Status Packet Result NO ERROR
	<p>Once locked, It is impossible to unlock unless the power is off.</p> <p>When other data is accessed while locked, an error is returned.</p>

4. Appendix

Range

Each data has valid range. When the Write command that is off the valid range is transmitted, an error is returned. The below table shows the length and range of data that the user can write. 16bit Data is displayed in two bytes, L and H. These two bytes should be written as one Instruction Packet at once.

[Control Table Data Range and Length for Writing]

Write Address	Writing Item	Length (bytes)	Min	Max
3(0X03)	ID	1	0	253(0xfd)
4(0X04)	Baud Rate	1	0	254(0xfe)
5(0X05)	Return Delay Time	1	0	254(0xfe)
6(0X06)	CW Angle Limit	2	0	1023(0x3ff)
8(0X08)	CCW Angle Limit	2	0	1023(0x3ff)
11(0X0B)	the Highest Limit Temperature	1	10(0x10)	99(0x63)
12(0X0C)	the Lowest Limit Voltage	1	50(0x32)	250(0xfa)
13(0X0D)	the Highest Limit Voltage	1	50(0x32)	250(0xfa)
14(0X0E)	Max Torque	2	0	1023(0x3ff)
16(0X10)	Status Return Level	1	0	2
17(0X11)	Alarm LED	1	0	127(0x7f)
18(0X12)	Alarm Shutdown	1	0	127(0x7f)
19(0X13)	(Reserved)	1	0	1
24(0X18)	Torque Enable	1	0	1
25(0X19)	LED	1	0	1
26(0X1A)	CW Compliance Margin	1	0	254(0xfe)
27(0X1B)	CCW Compliance Margin	1	0	254(0xfe)
28(0X1C)	CW Compliance Slope	1	1	254(0xfe)
29(0X1D)	CCW Compliance Slope	1	1	254(0xfe)
30(0X1E)	Goal Position	2	0	1023(0x3ff)
32(0X20)	Moving Speed	2	0	1023(0x3ff)
34(0X22)	Torque Limit	2	0	1023(0x3ff)
44(0X2C)	Registered Instruction	1	0	1
47(0X2F)	Lock	1	0	1
48(0X30)	Punch	2	0	1023(0x3ff)

RS485 UART

RS485 UART is a serial communication method that TxD and RxD cannot be executed simultaneously. It is usually used when connecting several communication equipments to one BUS. Since multiple devices are connected to the same BUS, all other devices should be in the input state while a device transmits. The communication direction of Main Controller controlling RX-10 is set as input and is changes to output only in the course of transferring Instruction Packet.

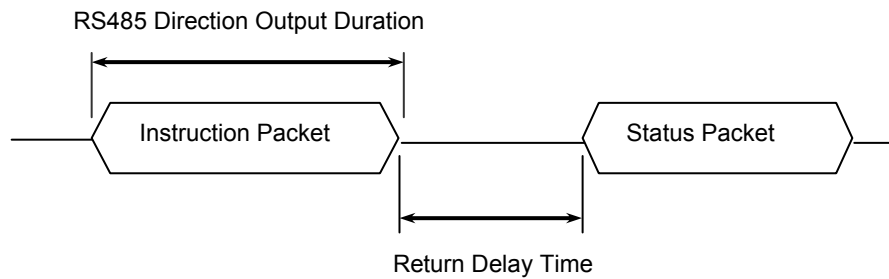

Return Delay Time

It is the time that takes to returns Status Packet after RX-10 receives Instruction Packet. Default value is 160uSec. Return Delay Time can be changed by changing the data of Control Table Address 5. Main Controller should convert Direction Port into the input state within the Return Delay Time frame after sending Instruction Packet.

Tx, Rx Direction

Rs485 UART should change Direction into the receiving mode at the time of finishing transmission. In general, CPU has the following BITs showing UART_STATUS in the register.

TXD_BUFFER_READY_BIT : It indicates the state that Transmission DATA can be loaded into Buffer. However, it does not mean that previously transmitted data is removed from CPU, but it means that SERIAL TX BUFFER is empty.

TXD_SHIFT_REGISTER_EMPTY_BIT : It is set when all Transmission Data is unloaded from CPU. In case of TXD_BUFFER_READY_BIT, this bit is used when sending a byte in serial communication as shown in the following example.

```
TxDByte(byte bData)
{
    while(!TXD_BUFFER_READY_BIT); //wait until data can be loaded.
    SerialTxDBuffer = bData;      //data load to TxD buffer
}
```

You should check TXD_SHIFT_REGISTER_EMPTY_BIT at the time of changing direction. The following example is a program sending Instruction Packet.

```

LINE 1  DIRECTION_PORT = TX_DIRECTION;
LINE 2  TxDByte(0xff);
LINE 3  TxDByte(0xff);
LINE 4  TxDByte(bID);
LINE 5  TxDByte(bLength);
LINE 6  TxDByte(bInstruction);
LINE 7  TxDByte(Parameter0); TxDByte(Parameter1); ...
LINE 8  DisableInterrupt(); // interrupt should be disable
LINE 9  TxDByte(Checksum); //last TxD
LINE 10 while(!TXD_SHIFT_REGISTER_EMPTY_BIT); //Wait till last data bit has been
sent
LINE 11 DIRECTION_PORT = RX_DIRECTION; //Direction change to RXD
LINE 12 EnableInterrupt(); // enable interrupt again
    
```

You should be careful of LINEs 8 to 12.

As for LINE 8, it is required since the front part of Status Packet is damaged if Interrupt Routine is performed longer than Return Delay Time due to the interruption happening when LINE 8 is executed.

Byte to Byte Time

It means the delay time between bytes when Instruction Packet is transmitted. When this time exceeds 100msec, RX-10 considers there is a transmission error and waits the header (0xff 0xff) of packet again.

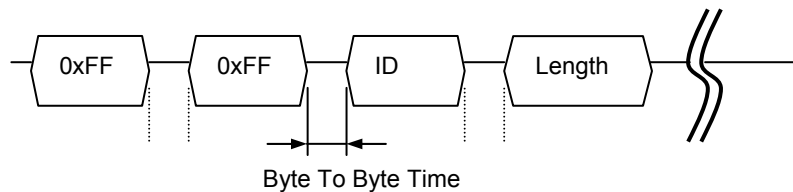

Connector

Company Name : Molex

Pin Number: 4 (or 5 for Optional VCC 5V)

Model Number

	Molex Part Number	Old Part Number
Male	22-03-5045	5267-04
Female	50-37-5043	5264-04

Temperature range : -40°C to +105°C

Contact Insertion Force-max : 14.7N (3.30 lb)

Contact Retention Force-min : 14.7N (3.30 lb)

For further information, please visit the website www.molex.com or www.molex.co.jp.

Female Connector

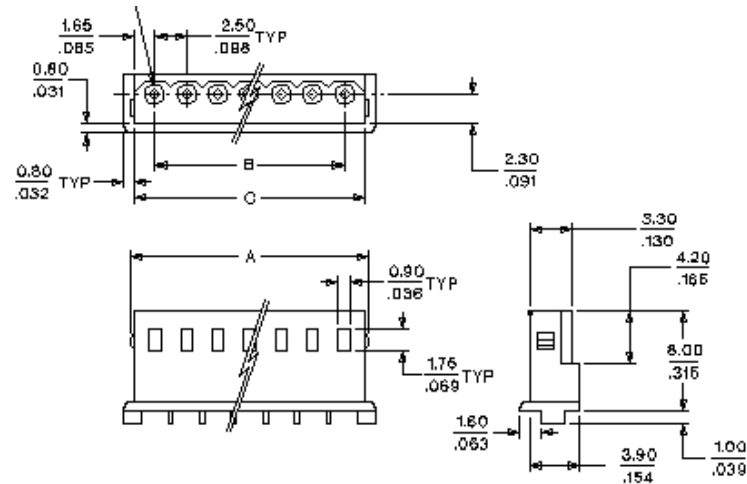

Male Connector

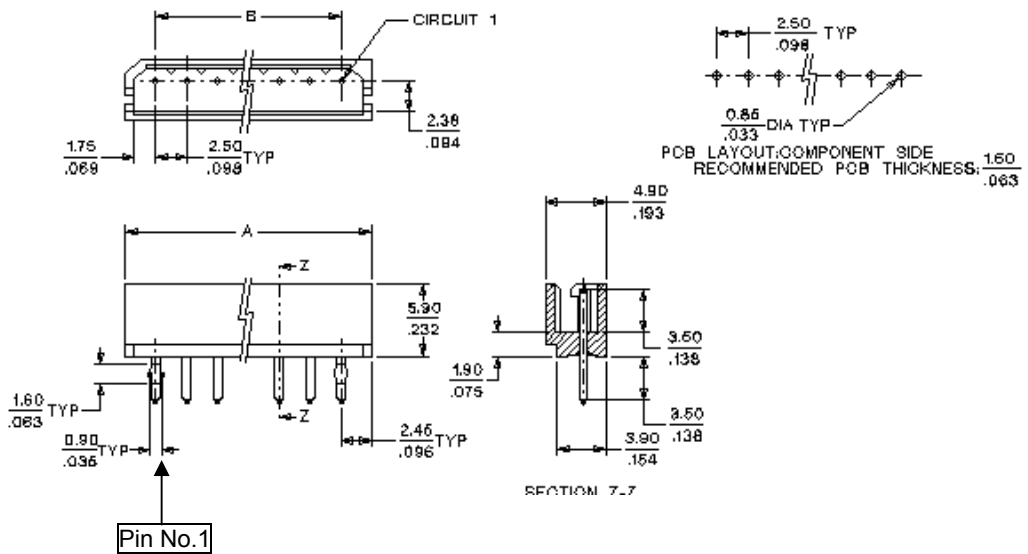

Dimension

