

AX-12A / AX18A Smart Robotic Arm Specifications / Advantages

There are two major advantages of the AX-12A / AX18 Smart Robotic Arm over other RC type (PWM) based robotic arms.

1. User configurable auto shutdown.
2. Real-time position, load, speed, voltage, and temperature status feedback.

The AX-12A / AX18A Advantage	AX Servo	R/C Servo
Temperature feedback	✓	✗
Position feedback	✓	✗
Speed feedback	✓	✗
Voltage feedback	✓	✗
Load feedback	✓	✗
Addressable	✓	✗
Single cable network connection	✓	✗
Auto shutdown	✓	✗
Error reporting	✓	✗
User configurable torque and compliance margins	✓	✗

- AX-12A Torque / Speed – AX-12A - 15kgf/cm and 59 rpm
- AX-18A Torque / Speed - AX-18A - 18kgf/cm and 97 rpm

AX-12A / AX-18A Smart Robotic Arm Specifications (standard arm)

- Overall length (from base) - 22.25" (56.51cm)
- Weight – 2.21 pounds / 1kg (Standard Smart Arm – no upgrades)
- Base height - 1" (2.54cm)
- The base rotation servo is centered in a 4" X 4" square (10.16cm X 10.16cm)
- Repeatability 2.5mm
- Each axis has a 300° range with 1024 steps (0.29°/step)
- Initial base angle can be set in 45° increments.
- Precision carbon steel ball bearing turntable
- Integrated pem nuts for quick and easy construction
- Super strong anodized 0.063 ga. 5052 brushed finished aluminum components
- Scratch resistant type II anodized in gun barrel gray
- (7) Dynamixel AX-12 / AX18 servos (5 axis + 1 gripper with standard Smart Robotic Arm configuration, 6- axis with 5-axis upgrade package)

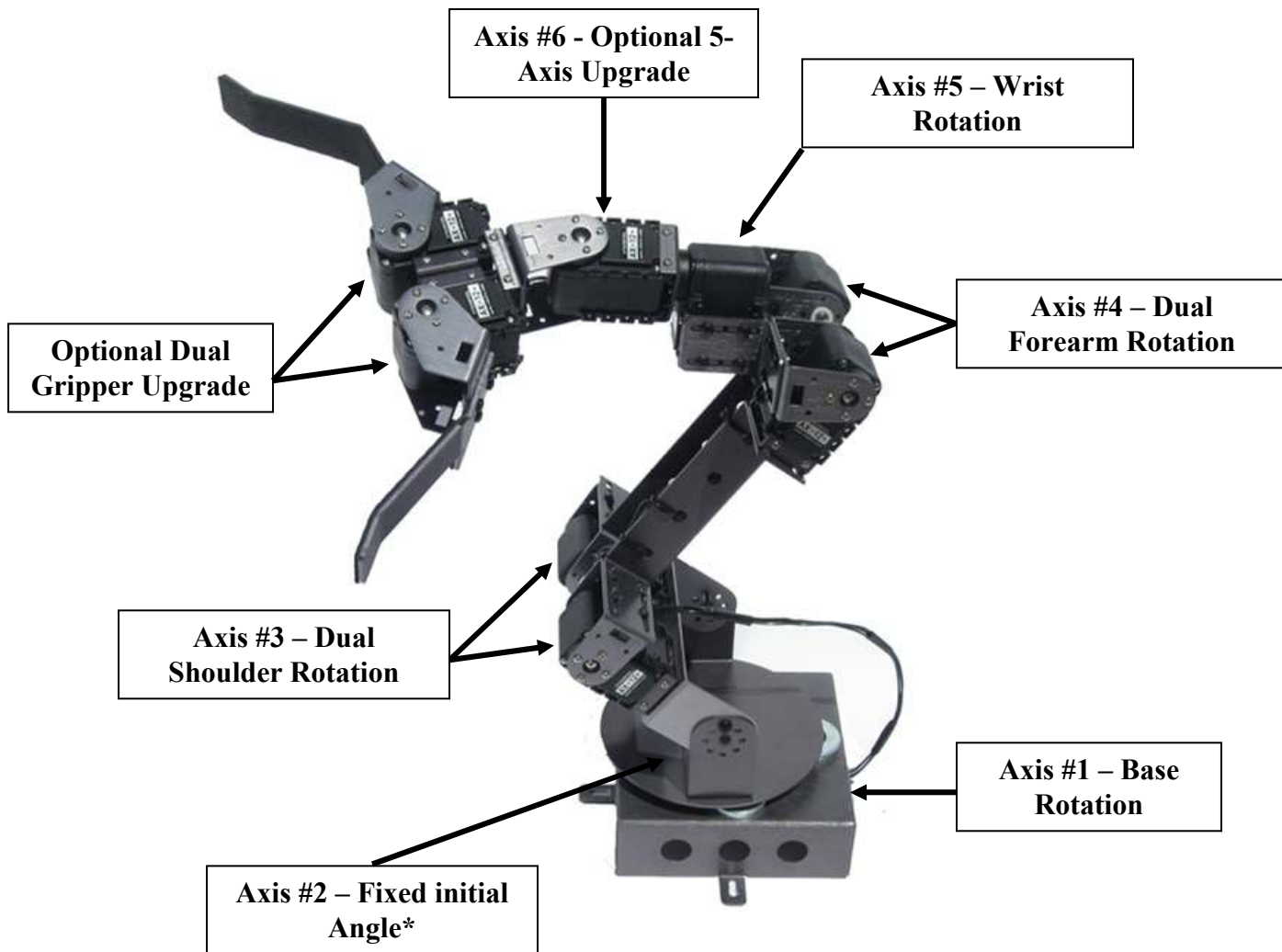

* **Note:** Axis #2 (fixed initial angle) can be replaced with dual AX-18A actuators with the 6-Axis Upgrade Package.

Dimensional Information

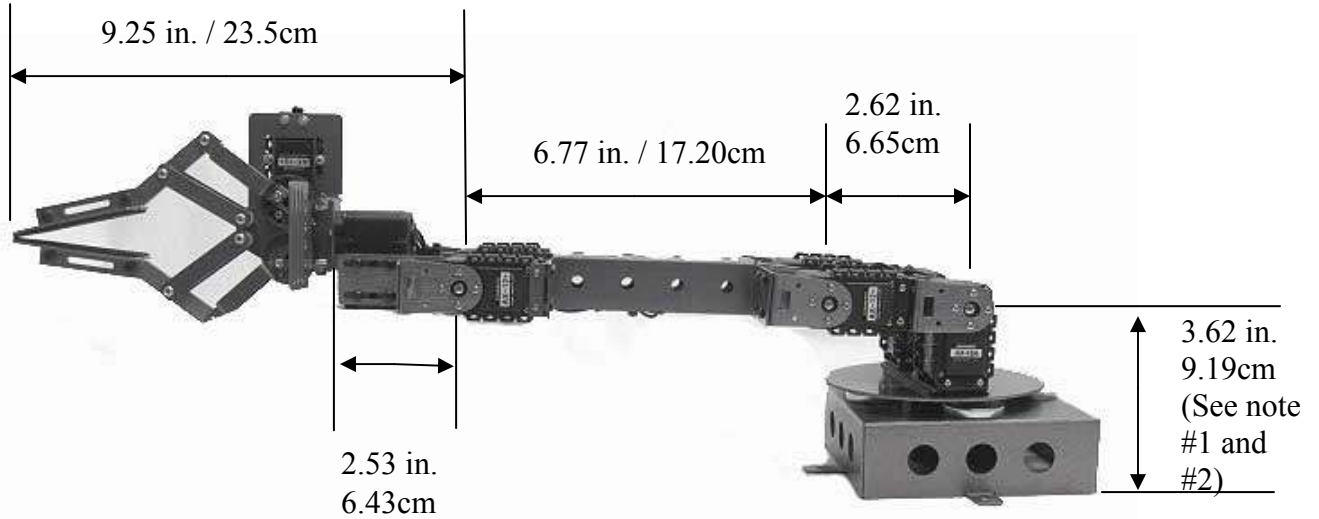

Overall Length – 22.26 in. / 56.54cm

Overall Weight – Standard Arm with fixed initial angle bracket - 2.0 pounds / 1kg

Overall Weight – Standard Arm with 6-axis upgrade - 2.62 pounds / 1.18 kg

Note #1 - Smart Robotic Arm shown with optional 6 axis upgrade**

Note #2 - With the standard fixed initial angle bracket the base to first fixed angle would be 3.375 in / 8.57cm

Standard Gripper

Standard Gripper

- Ships with all AX-12A and AX-18A Smart Robotic Arms
- Sensor engineered gripper design
- Built in, adjustable camera / sensor mount
- Slotted gripper paddles for easy sensor attachment
- High resolution, 60 tooth, heavy duty gear train
- 2.375" (6cm) Standard Gripper opening / 9" (22.86cm) gripper opening with dual gripper upgrade option
- Cross cut, high adhesion rubber for maximum gripper adhesion



Figure 1 - CCD Camera



Figure 2 - PING Ultrasonic Sensor

Turntable

- Stainless steel, sealed ball bearing turntable
- 3- integrated mounting tabs for easy mounting to any base
- Base Size – 4.5" X 4.5" (11.43cm X 11.43cm)

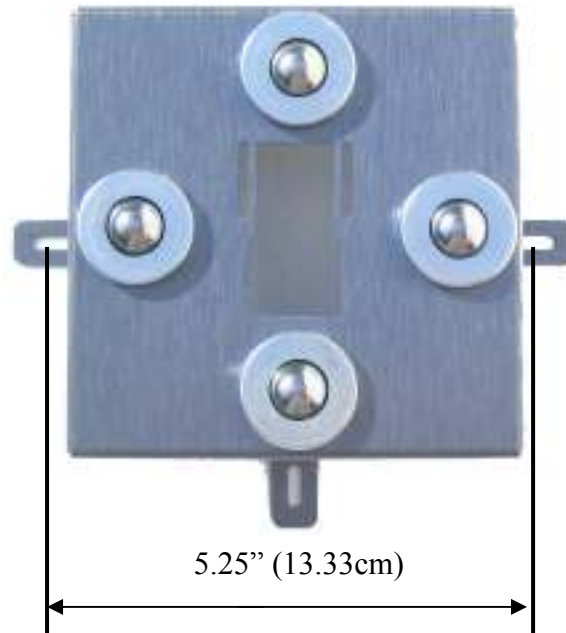

Adjustable Initial Angles (standard with all robotic arms)

- Adjustable initial angle in 45 degree increments. The adjustable initial angle can be upgraded to the 6-axis upgrade which includes a dual AX-18A axis as shown in figure 4.

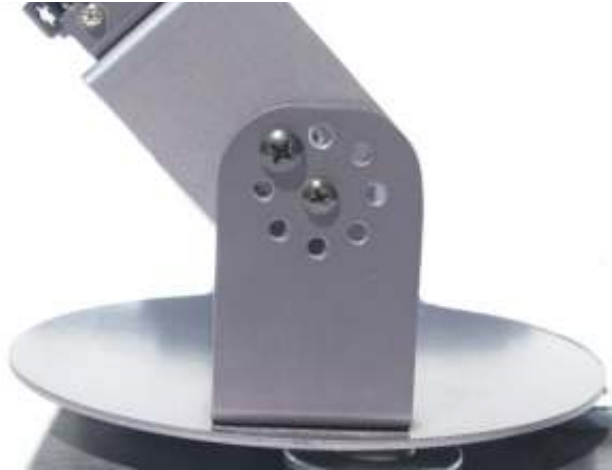

Figure 3 - Adjustable Initial Angle



Figure 4 - 6-Axis Upgrade replaces the Adjustable Initial Angle hardware



Accessories / Controllers / Software

Crustcrawler offers a complete line of accessories for you to enhance and customize your AX-12A or AX-18A Smart Robotic arm. Please scroll down on the AX-12A or AX-18A Smart robotic arm product pages to review and purchase Smart Arm accessories.

Grippers

Dual Gripper

The AX-12A or AX-18A dual gripper kit provides a large 9 inch (22.86cm) gripper opening for grasping larger objects. Powered by dual AX-12A or AX-18A servos, the dual gripper kit provides plenty of power for grasping and holding larger objects.

Accessories	
Kit	Part Number / Description
 AX-12A Dual Gripper Hardware Kit	DGK <ul style="list-style-type: none">• (1) AX-12A Dual Gripper Hardware kit• This kit does not include servos!• AX-12A/AX-18A Dual Gripper Information
 AX-12A Dual Gripper Full Kit	DGK2 <ul style="list-style-type: none">• (1) AX-12A Dual Gripper Hardware kit• (2) AX-12A servos• AX-12A/AX-18A Dual Gripper Information
 AX-18A Dual Gripper Full Kit	DGK18FFK <ul style="list-style-type: none">• (1) AX-12A Dual Gripper Hardware kit• (2) AX-18A servos (for more speed and torque!)• AX-12A/AX-18A Dual Gripper Information

Big Grip Gripper

The Big Grip gripper is ideal for picking up large round or square objects and is either powered by a single AX-12A or an AX-18A servo.

Big Grip Hardware Kit (bgh)



BGH

- (1) Big Grip aluminum hardware kit.
- **This kits does not include servos!**
- [AX-12A/AX-18A Big Gripper Information](#)

Big Grip with an AX-12A Smart Servo (bgax)



BGAX

- (1) Big Grip aluminum hardware kit.
- (1) AX-12A Smart Servo.
- [AX-12A/AX-18A Big Gripper Information](#)

Big Grip with an AX-18A Smart Servo (bgax18f)



BGAAX18F

- Get even more torque and more speed with the AX-18A servo!
- (1) Big Grip aluminum hardware kit.
 - (1) AX-18A Smart Servo.
 - [AX-12A/AX-18A Big Gripper Information](#)

5 and 6 Axis Upgrades

5 Axis Upgrade

Crustcrawler 5-Axis and 6-Axis upgrades add another single or dual axis of motion to your Smart Robotic Arm giving it more reach and versatility. The 5 Axis upgrade is installed behind the gripper and allows for 112 degrees of additional wrist motion from any direction in 3D space along with the standard 320 degree wrist rotate, and up/down motion for true 3-dimensional movement of the end effector or gripper.

5-Axis Upgrade Hardware kit



5axisupgradehw

Upgrade the AX-18A Smart Robotic Arm to a 5-axis kit! This kit installs directly behind the gripper. This kit requires an AX-12A or AX-18A servo.

- (1) SSB Short Bracket
- (1) SSB Side Bracket
- (1) Screw Set
- [5-Axis Upgrade Manual](#)

5-Axis Upgrade with AX-12A Servo



5axisupgradekit

Upgrade the AX-18A Smart Robotic Arm to a 5-axis kit! This kit installs directly behind the gripper.

- (1) SSB Short Bracket
- (1) SSB Side Bracket
- (1) Screw Set
- (1) AX-12A Servo
- [5-Axis Upgrade Manual](#)

5-Axis Upgrade with AX-18A Servo



5axisupgradeax18A

Upgrade the AX-18A Smart Robotic Arm to a 5-axis kit! This kit installs directly behind the gripper.

- (1) SSB Short Bracket
- (1) SSB Side Bracket
- (1) Screw Set
- (1) AX-18A Servo
- [5-Axis Upgrade Manual](#)

6 Axis Upgrade

The 6 Axis upgrade replaces the Fixed Initial Angle hardware above the turntable (standard for all kits) and provides a powerful dual axis powered by AX-18A servos.

6-Axis Upgrade Hardware kit



6axisupgradehdw

Upgrade the AX-18A Smart Robotic Arm to a 6-axis arm! This kit replaces the initial angle hardware to provide a 6th axis.

- (2) SSB Short Bracket
- (2) SSB Side Bracket
- (1) 6-axis mounting plate
- (1) mounting screw set
- Note: This kit requires (2) AX-18A servos
- [6-Axis Upgrade Manual](#)

6-Axis Upgrade with dual AX-18A Servos



6axisupgradeAX

Upgrade the AX-18A Smart Robotic Arm to a 6-axis arm! This kit replaces the initial angle hardware to provide a 6th axis.

- (2) SSB Short Bracket
- (2) SSB Side Bracket
- (1) 6-axis mounting plate
- (1) mounting screw set
- (2) AX-18A servos
- [6-Axis Upgrade Manual](#)

Power Supplies / Sensors

For a complete “turn key” solution, be sure to purchase the AX-12A/AX-18A power supply and power supply harness. The Flexiforce sensor is an excellent pressure sensor that can be installed onto any of Crustcrawler gripper kits.

AX-12A/AX-18A Power Supply



AX-12A/AX-18A Power Supply

- 9 Volt/6amp power supply provides plenty of power for the AX-18A Smart Robotic Arm
- (1) 9Volt/6Amp Power Supply (requires AX12A/AX18A Power Harness)

AX-12A/AX-18A Power Harness



AX-12A/AX-18A Power Harness

- The AX-12 power harness makes powering the AX-12A / AX-18A Smart Robotic Arm or any AX-12A/ AX-18A network quick and easy! Combine this connector with CrustCrawler's AX-12A/AX-18A power supply for a complete AX power system.
- (1) Power Harness
 - (1) 2.1mm male P5 barrel plug
 - (2) 3 pin molex connectors for easy AX-12A / AX-18A and USB2Dynamixel connections

Flexiforce Pressure Sensor



Flexiforce Pressure Sensor

- The active sensing area is a .375" diameter circle at the end of the sensor. The conductive leads are easy to connect to a breadboard or through-hole area. The Flexiforce has an ideal output for A/D conversion - 0V is no force and 4.2V is 100 lbs. The RCTIME command may be used with a LOOKUP table or calibration formula to execute some math to make the output useful.
- (1) Flexiforce Pressure Sensor

Ping Ultra Sonic Sensor



Ping Ultra Sonic Sensor

- (1) Ping Ultra Sonic Sensor
- [PING Documentation](#)
- [Detecting Distance With the PING Sensor](#)
- [Basic Stamp Sample Code](#)

Controllers

Both the AX-12A and AX-18A Smart Robotic Arms are **open source platforms**. Control of the arm only requires a serial connection to a microcontroller or computer. Software and programming platforms can be of the users choosing. Popular programs including Matlab and LabView all have the abilities to control Crustcrawler line of Smart Robotic arms.

The USB2Dynamixel interface (shown below) along with Crustcrawler's AX-12A/AX-18A Power supply and power harness is our best selling combination. The USB2dynamixel provides the connection to a microcontroller or computer via its USB port allowing you to control the Smart Robotic arm from the programming platform of your choosing.

Controller	Details
CM-700 Controller 	<ul style="list-style-type: none">• (1) CM-700 Control Module• (1) CD-ROM with CM-700 Control Software including RoboPlus Task, Motion and Manager Control programs• (1) Mounting Screw / nut kit• (1) Interface cable•  CM-700 Users Guide and Technical Specifications• See the CM-700 Product Page for more information.
LN-101 USB Downloader 	<ul style="list-style-type: none">• This special USB connector is required to connect the CM-700 to a computer USB port.• (1) LN-101 USB Downloader• (1) 100cm USB cable•  LM-101 Users Guide
USB2Dynamixel 	<ul style="list-style-type: none">• USB2Dyanmixel provides USB to RS-232, RS-485, and AX-12 (TTL) interfaces in one unit.• (1) USB2dynamixel Controller• (1) USB cable• See the USB2Dynamixel Product Page for more information.