

**S E A C O N**®



# Micro **WET-CON** SERIES

---

UNDERWATER ELECTRICAL WET-MATE CONNECTORS

| SECTION   | PAGE      |
|---|-----------|
| <b>Micro WET-CON</b>                            |           |
| Product News - Connector Enhancements.....      | MWC 3     |
| Introduction .....                              | MWC 4     |
| Availability .....                              | MWC 4     |
| Applications .....                              | MWC 4     |
| Special Assemblies .....                        | MWC 4     |
| Part Number System .....                        | MWC 4     |
| General Information .....                       | MWC 5     |
| Ampacity Chart for Standard Parts .....         | MWC 5     |
| Standard Wiring Color Code .....                | MWC 5     |
| Dimension Details:                              |           |
| MC-BH-M (2 to 8 Contacts) .....                 | MWC 6     |
| MC-BH-F (2 to 8 Contacts) .....                 | MWC 6     |
| MC-BH-M (10 to 16 Contacts) .....               | MWC 7     |
| MC-BH-F (10 to 16 Contacts) .....               | MWC 7     |
| MC-BH-M-DO (2 to 8 Contacts) .....              | MWC 8     |
| MC-BH-F-DO (2 to 8 Contacts) .....              | MWC 8     |
| MC-BH-M-DO (10 to 16 Contacts) .....            | MWC 9     |
| MC-BH-F-DO (10 to 16 Contacts) .....            | MWC 9     |
| MC-IL-M (2 to 8 Contacts) .....                 | MWC 10    |
| MC-IL-F (2 to 8 Contacts) .....                 | MWC 10    |
| MC-IL-M (10 to 16 Contacts) .....               | MWC 11    |
| MC-IL-F (10 to 16 Contacts) .....               | MWC 11    |
| MC-DC-M (2 to 8 Contacts) .....                 | MWC 12    |
| MC-DC-F (2 to 8 Contacts) .....                 | MWC 12    |
| MC-DC-M (10 to 16 Contacts) .....               | MWC 13    |
| MC-DC-F (10 to 16 Contacts) .....               | MWC 13    |
| MC-DLS-M (2 to 8 Contacts) .....                | MWC 14    |
| MC-DLS-F (2 to 8 Contacts) .....                | MWC 14    |
| DLSA-M (10 to 16 Contacts) .....                | MWC 14    |
| DLSA-F (10 to 16 Contacts) .....                | MWC 14    |
| Interface Details .....                         | MWC 15    |
| Contact Configurations .....                    | MWC 16    |
| <b>Micro WET-CON SPLIT SERIES SECTION</b> ..... | MWC 17-23 |

## PRODUCT NEWS

# Micro WET-CON and Micro WET-CON SPLIT SERIES CONNECTOR ENHANCEMENTS

### INTRODUCTION

As part of our continuous improvement process the SEA CON® Group consistently reviews its product ranges through both customer feedback and internal improvements. It is via these processes that SEA CON® identified a design enhancement to the Micro WET-CON connector ranges. This new design improvement has now been implemented not only across this connector range, but also the new Micro WET-CON Split Series.

### DESIGN FEATURES

The design change is associated with the Male Pin connectors only and has been introduced to improve and extend the life of the connectors by decreasing the stresses that are applied to the sealing interface between the male contact pin and the sealing rubber around the pin during the connectors mate and de-mate cycles.

The newly designed male contact has a "Lead in" as part of the contact pin itself which replaces the current rubber lead in. The introduction of the new pin removes any potential wear to the sealing interface between the male contact pin and the sealing rubber around the pin which may occur with many repeated make and breaks of the connector pairs. The new pin will maintain the full connector sealing properties and will provide a greater life expectancy of the connectors.

The incorporation of this design change to the Male Pin connectors will not affect the existing Female Socket connectors currently being used by SEA CON®'s customers and therefore full intermateability will be maintained. In addition, SEA CON® would also like to confirm that pricing will also not be affected.

### TESTING

This new pin design concept has been fully tested and has been utilized in both the U-MATE and SEA-MATE connector ranges for a number of years.

### MCAT ATTACHABLE Micro WETCON

Due to global demand to terminate standard rubber molded connectors onto specialized or customer furnished cable, SEA CON Global Production has introduced an MCAT version of the successful Micro WET-CON connector series.

This new connector can be terminated virtually anywhere eliminating the need for shipping bulky long lengths of cable. In addition the end user is able to produce a reduced length termination without the need for additional cable splices and have one continuous cable diameter for the total length of the cable.

The MCAT connector is fully inter-mateable with like configured Micro WET-CON inline and bulkhead connectors. For further information and for cable jacket materials that can be accommodated please contact SEA CON®.



**INTRODUCTION**

The Micro WET-CON connector series was developed to provide all the features of SEA CON®'s ALL-WET connector series, but in a miniature, industry standard configuration. The small size offers the same flexibility and reliability as our rubber molded connectors, in a light-weight and user friendly model.

The Micro WET-CON series allows for smaller through ports in a pressure vessel and a greater density of conductors in a compact area. The smaller cables decrease the overall weight and drag of an ROV or other vessel. This connector range is wet-mateable and therefore enables connections to be made underwater, on-deck or in any weather condition.

**AVAILABILITY**

The Micro WET-CON series is a stocked item, which ensures quick delivery (in reasonable quantities) of standard configurations. Custom cable lengths are available upon request. Shorting plugs are available should you require the ability of looping together 'like' circuits for testing purposes within the dummy. Pin to pin shorting details need to be supplied at time of order placement.

**MATERIALS**

The Micro WET-CON is made from a proprietary grade Neoprene. The standard locking sleeves are Delrin® (DuPont trademark for Acetal Resin), which is lightweight, durable and user-friendly in the working environment (Brass and Stainless Steel are also available upon request).

**APPLICATIONS**

Possible applications include: underwater television and lights, diver communications, ROV systems, submersibles, towed-array cable systems, current meters, animal migration research and food processing equipment.

**TESTING**

The Micro WET-CON range has undergone complete Qualification testing including low pressure soak tests, full mate/de-mate and high pressure cycling to 10,000 psi.

**SPECIAL ASSEMBLIES**

SEA CON® maintains all facilities necessary to furnish complete underwater and environmental electrical connector/cable systems, including Research and Development, Engineering, Manufacturing, Quality Control and Pressure Testing.

As well as supplying our standard 'off-the-shelf' items, we have the capability to design and manufacture **SPECIAL CUSTOMIZED CONNECTORS AND CABLE ASSEMBLIES** to suit your individual needs.

SEA CON® also prides itself with the ability to perform stringent quality conformance testing procedures which are in accordance with the MIL-SPEC programs.

**PART NUMBER SYSTEM - EXAMPLE**

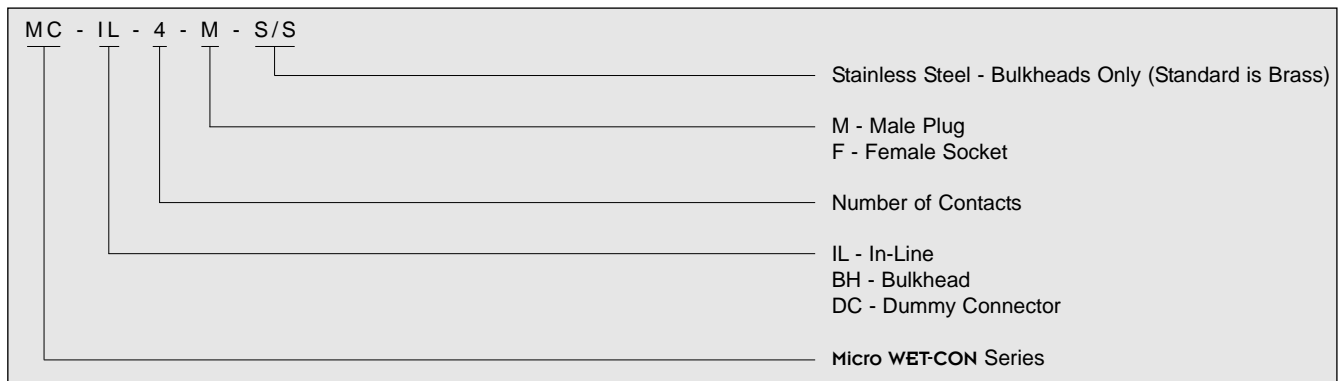

**NOTES:**

- For Locking Sleeves see page MWC 14.

**GENERAL INFORMATION**

| COMPONENT   | MATERIAL   |
|---|--|
| MOLDED BODY   | Neoprene   |
| BULKHEAD BODY   | Brass (CA #360)  |
| CONTACTS  | Brass-gold plated (CA #360)  |
| GUIDE PINS  | Stainless Steel (303 SS or 304 SS)   |
| BULKHEAD N & W  | Brass (CA #360)  |
| O-RING  | Nitrile (formerly known as Buna N)   |
| LOCKING SLEEVE  | Delrin® (DuPont trademark for Acetal Resin)  |
| IN-LINE CABLE<br>(2, 3 & 4 PIN):<br>(5, 6, 8, 10, 12 & 16 PIN):<br>STANDARD LENGTH: | Neoprene, #18 AWG (SO Cable)<br>Neoprene, #20 AWG<br>24 inches (60cm)                  |
| HOOK-UP WIRE (BC)   | Teflon® (Registered trademark for DuPont), #20 AWG<br>Standard length 13 inches (33cm) |

| CATEGORY              | VALUE  |
|-----------------------|--|
| OPEN FACE PRESSURE    | 10,000 psi (700 bar) optional and needs to be specified<br>Dummy cap recommended above 100 psi |
| MATED PRESSURE        | 10,000 psi (700 bar)   |
| VOLTAGE RATING        | 2, 3 & 4 pin 600 VDC<br>5, 6, 8, 10, 12 & 16 pin 300 VDC                                       |
| CURRENT RATING        | Up to 19 amps per contact  |
| INSULATION RESISTANCE | >200 megohms @ 300 VDC   |
| CONTACT RESISTANCE    | <0.01 ohms   |
| AIR MATE              | >1,000 cycles  |
| UNDERWATER MATE       | >500   |
| OPERATING TEMPERATURE | 25° to 140°F (-4° to 60°C)   |
| MOUNTING TORQUE       | 85 in-lb*<br>In dry stainless 1/2" long Female threads   |

**NOTES:**

- Contact SEA CON® for special order materials.
- Incorporation of special order cables will be determined on a case by case basis.
- Connectors are designed for installation on one atmosphere vessels. Contact SEA CON® for recommendations if using compensated vessels.
- \* For metal shells only, for other materials contact SEA CON® for recommendations.

**AMPACITY CHART FOR STANDARD PARTS (18 & 20 AWG SO CABLE)**

| PART DESCRIPTION<br>NUMBER OF CONTACTS | AMPACITY |
|--|----------|
| MCBH/IL-2                              | 10 amps  |
| MCBH/IL-3                              | 6 amps   |
| MCBH/IL-4                              | 6 amps   |
| MCBH/IL-5                              | 3 amps   |
| MCBH/IL-6                              | 3 amps   |

| PART DESCRIPTION<br>NUMBER OF CONTACTS | AMPACITY |
|--|----------|
| MCBH/IL-8                              | 3 amps   |
| MCBH/IL-10                             | 2.5 amps |
| MCBH/IL-12                             | 2.5 amps |
| MCBH/IL-16                             | 2 amps   |

**STANDARD IN-LINE WIRING COLOR CODE (SO CABLE)**

| CONTACT # | COLOR       |
|-----------|-------------|
| 1         | BLACK       |
| 2         | WHITE       |
| 3         | RED **      |
| 4         | GREEN       |
| 5         | ORANGE      |
| 6         | BLUE        |
| 7         | WHITE/BLACK |
| 8         | RED/BLACK   |

| CONTACT # | COLOR        |
|-----------|--------------|
| 9         | GREEN/BLACK  |
| 10        | ORANGE/BLACK |
| 11        | BLUE/BLACK   |
| 12        | BLACK/WHITE  |
| 13        | RED/WHITE    |
| 14        | GREEN/WHITE  |
| 15        | BLUE/WHITE   |
| 16        | BLACK/RED    |

**NOTE:**

- \*\* For 3 contact configurations wiring color code is GREEN.

**Micro WET-CON SERIES  
MC-BH-M  
(2 - 8 contacts)**

Micro WET-CON Bulkhead Connector Male Plug  
Mates with MC-IL-F  
Dummy Connector: MC-DC-F

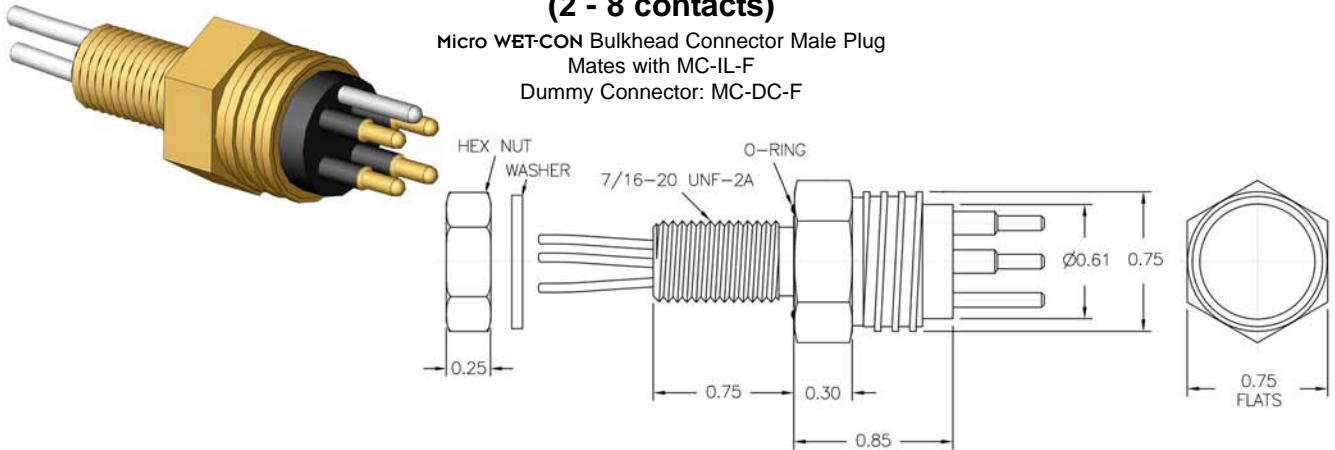

**Micro WET-CON SERIES  
MC-BH-F  
(2 - 8 contacts)**

Micro WET-CON Bulkhead Connector Female Socket  
Mates with MC-IL-M  
Dummy Connector: MC-DC-M

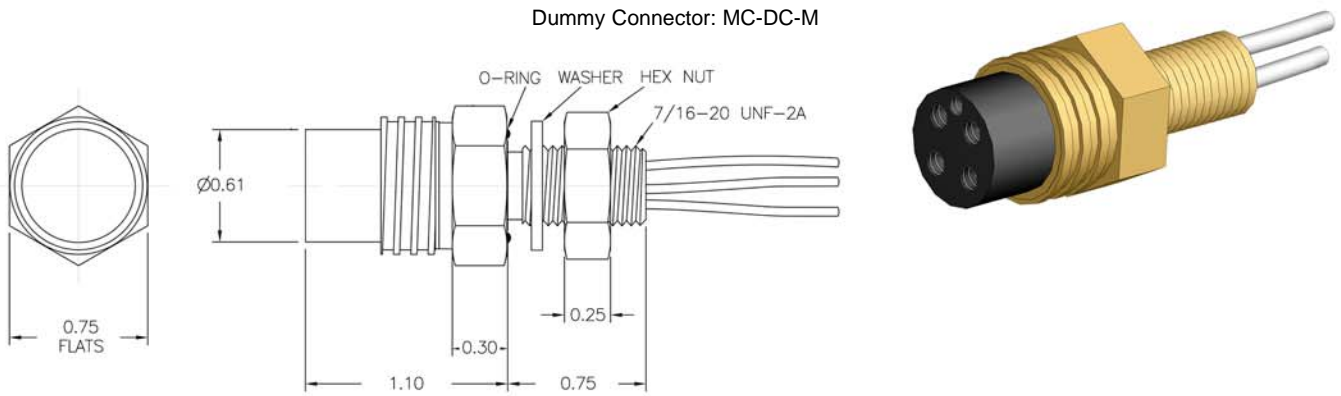

**Micro WET-CON SERIES  
HEX NUT AND WASHER  
(2 - 8 contacts)**

Micro WET-CON Bulkhead Connector

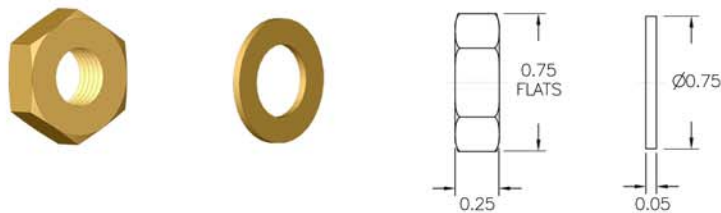

STD - BRASS  
(Stainless Steel and others upon request)

**NOTES:**

- Hex Nut and Washer: Optional.
- O-Ring: 2-014.
- Dummy Connector: Optional.
- Dummy Shorting Plug Connector: Optional.
- Connectors must be lubricated prior to mating.
- Torque values referenced in this literature assume installation into dry metal threads. For other applications, please contact SEA CON® for recommendations.
- Connectors are designed for installation on one atmosphere vessels. Contact SEA CON® for recommendations if using compensated vessels.

**Micro WET-CON SERIES  
MC-BH-M  
(10 - 16 contacts)**

Micro WET-CON Bulkhead Connector Male Plug  
Mates with MC-IL-F  
Dummy Connector: MC-DC-F

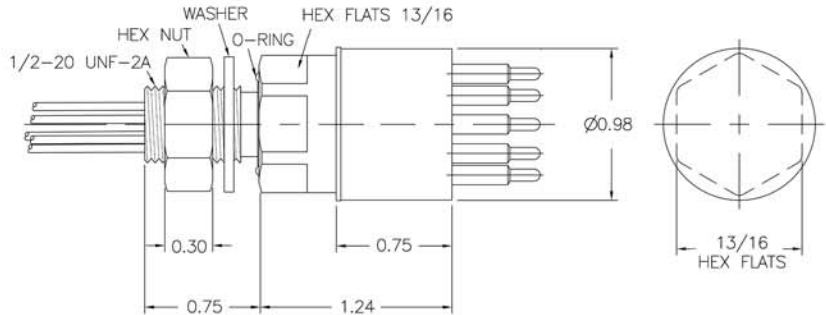
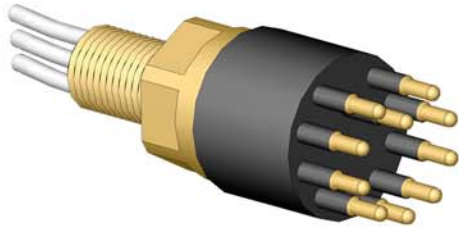

**Micro WET-CON SERIES  
MC-BH-F  
(10 - 16 contacts)**

Micro WET-CON Bulkhead Connector Female Socket  
Mates with MC-IL-M  
Dummy Connector: MC-DC-M

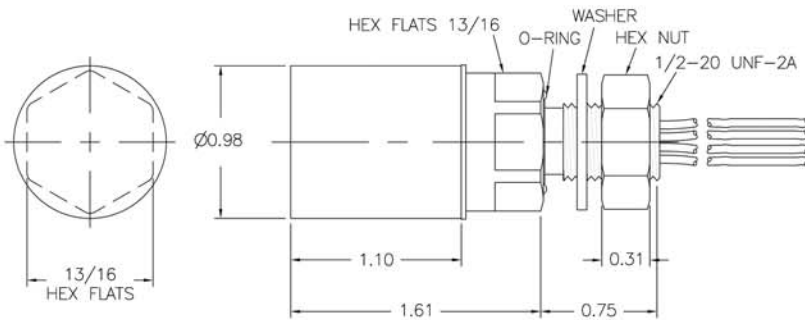

**Micro WET-CON SERIES  
HEX NUT AND WASHER  
(10 - 16 contacts)**

Micro WET-CON Bulkhead Connector

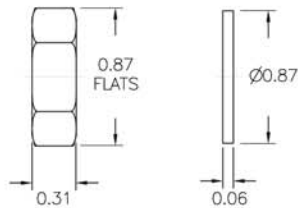

STD - BRASS  
(Stainless Steel and others upon request)

**NOTES:**

- Hex Nut and Washer: Optional.
- O-Ring: 2-015.
- Dummy Connector: Optional.
- Dummy Shorting Plug Connector: Optional.
- Connectors must be lubricated prior to mating.
- Torque values referenced in this literature assume installation into dry metal threads. For other applications, please contact SEA CON® for recommendations.
- Connectors are designed for installation on one atmosphere vessels. Contact SEA CON® for recommendations if using compensated vessels.

### Micro WET-CON SERIES MC-BH-M-DO (DOUBLE O-RING) (2 - 8 contacts)

Micro WET-CON Bulkhead Connector Male Plug with Double O-Ring  
Mates with MC-IL-F  
Dummy Connector: MC-DC-F

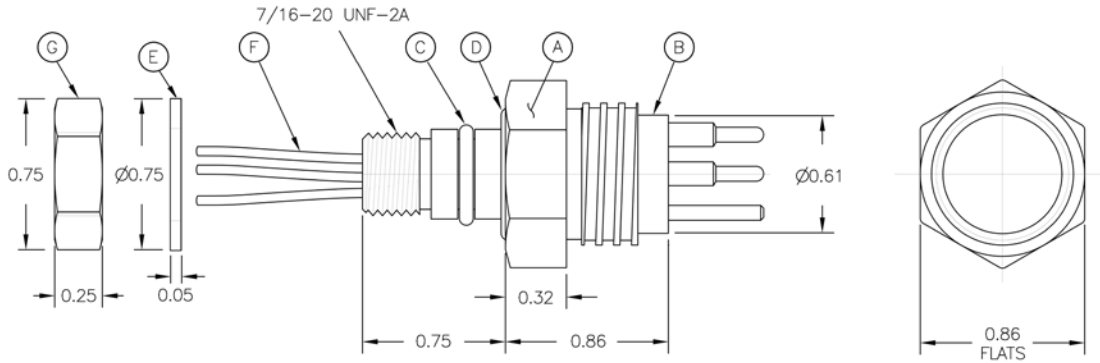

### Micro WET-CON SERIES MC-BH-F-DO (DOUBLE O-RING) (2 - 8 contacts)

Micro WET-CON Bulkhead Connector Female Socket with Double O-Ring  
Mates with MC-IL-M  
Dummy Connector: MC-DC-M

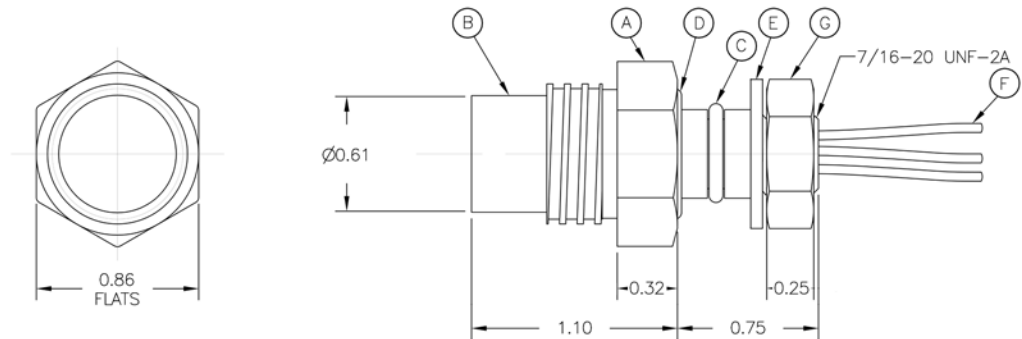

| PART NUMBER | PART DESCRIPTION          |
|-------------|---------------------------|
| A           | MC-BH DOUBLE O-RING SHELL |
| B           | NEOPRENE MOLDING          |
| C           | O-RING 2-012              |
| D           | O-RING 06-10525-1         |
| E           | WASHER                    |
| F           | BULKHEAD LEADS            |
| G           | HEX NUT 7/16 - 20         |

**NOTES:**

- Hex Nut and Washer: Optional.
- Dummy Connector: Optional.
- Dummy Shorting Plug Connector: Optional. (Shorting plugs are available should you require the ability of looping together 'like' circuits for testing purposes within the dummy. Pin to pin shorting details need to be supplied at time of order placement).
- Connectors must be lubricated prior to mating.
- Torque values referenced in this literature assume installation into dry metal threads. For other applications, please contact SEA CON® for recommendations.
- Connectors are designed for installation on one atmosphere vessels. Contact SEA CON® for recommendations if using compensated vessels.



### Micro WET-CON SERIES MC-BH-M-DO (DOUBLE O-RING) (10 - 16 contacts)

Micro WET-CON Bulkhead Connector Male Plug with Double O-Ring  
Mates with MC-IL-F  
Dummy Connector: MC-DC-F

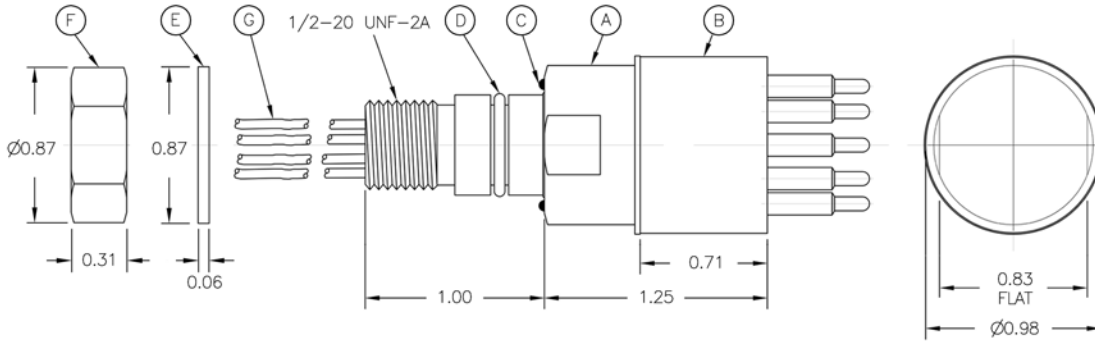

### Micro WET-CON SERIES MC-BH-F-DO (DOUBLE O-RING) (10 - 16 contacts)

Micro WET-CON Bulkhead Connector Female Socket with Double O-Ring  
Mates with MC-IL-M  
Dummy Connector: MC-DC-M

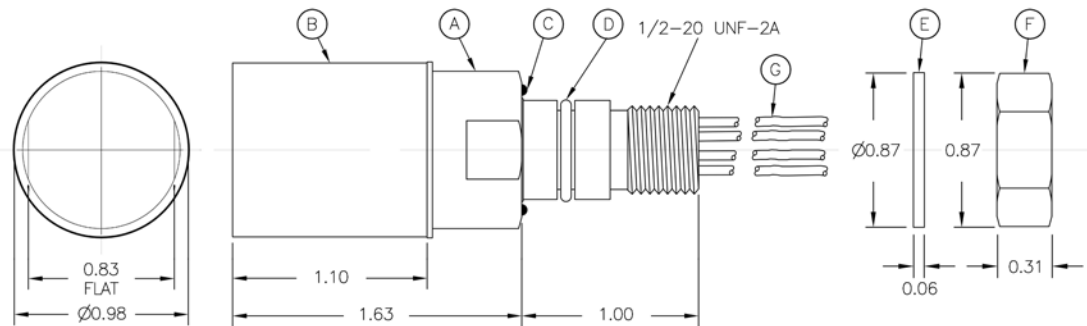

| PART NUMBER | PART DESCRIPTION          |
|-------------|---------------------------|
| A           | MC-BH DOUBLE O-RING SHELL |
| B           | NEOPRENE MOLDING          |
| C           | O-RING 06-10583-1         |
| D           | O-RING 06-10437-1         |
| E           | WASHER                    |
| F           | HEX NUT 1/2-20            |
| G           | BULKHEAD LEADS            |

**NOTES:**

- Bulkhead Locking Sleeve: Optional.
- Hex Nut and Washer: Optional.
- Dummy Connector: Optional.
- Dummy Shorting Plug Connector: Optional. (Shorting plugs are available should you require the ability of looping together 'like' circuits for testing purposes within the dummy. Pin to pin shorting details need to be supplied at time of order placement).
- Connectors must be lubricated prior to mating.
- Torque values referenced in this literature assume installation into dry metal threads. For other applications, please contact SEA CON® for recommendations.
- Connectors are designed for installation on one atmosphere vessels. Contact SEA CON® for recommendations if using compensated vessels.

**Micro WET-CON SERIES  
MC-IL-M  
(2 - 8 contacts)**

Micro WET-CON In-Line Connector Male Plug  
Mates with MC-IL-F & MC-BH-F  
Dummy Connector: MC-DC-F

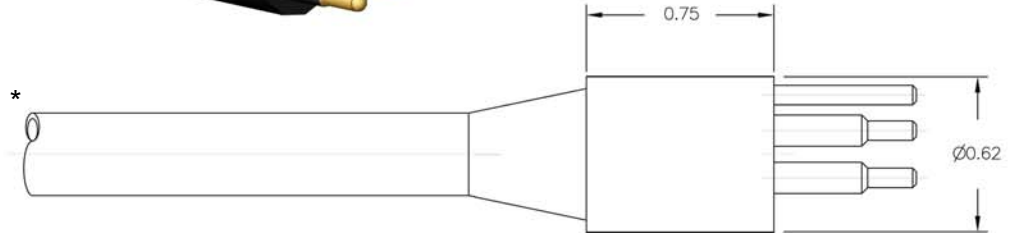

**Micro WET-CON SERIES  
MC-IL-F  
(2 - 8 contacts)**

Micro WET-CON In-Line Connector Female Socket  
Mates with MC-IL-M & MC-BH-M  
Dummy Connector: MC-DC-M

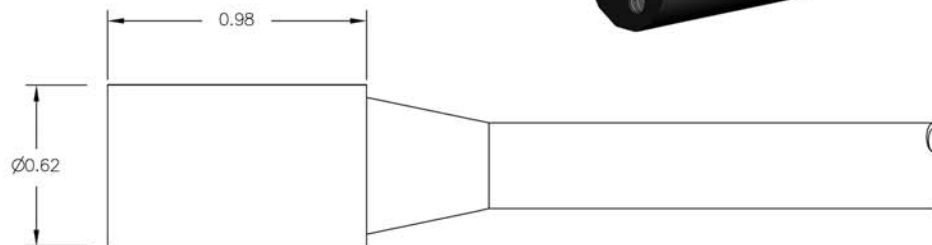

**NOTES:**

- Locking Sleeve: Optional (see page MWC 14).
- Dummy Connector: Optional.
- Dummy Shorting Plug Connector: Optional. (Shorting plugs are available should you require the ability of looping together 'like' circuits for testing purposes within the dummy. Pin to pin shorting details need to be supplied at time of order placement).
- Connectors must be lubricated prior to mating.
- \* Incorporation of special order cables will be determined on a case-by-case basis.

**Micro WET-CON SERIES  
MC-IL-M  
(10 - 16 contacts)**

Micro WET-CON In-Line Connector Male Plug  
Mates with MC-IL-F & MC-BH-F  
Dummy Connector: MC-DC-F

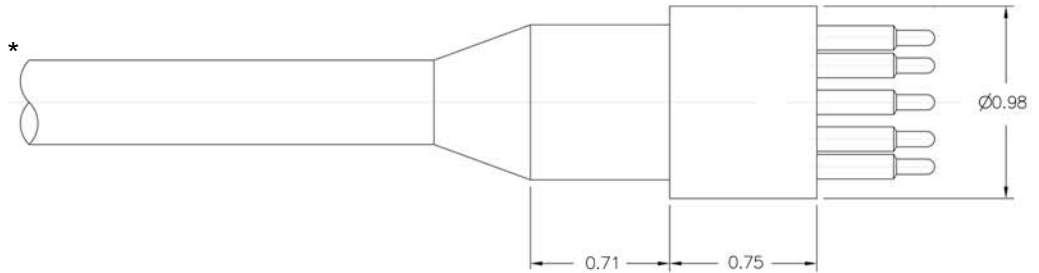
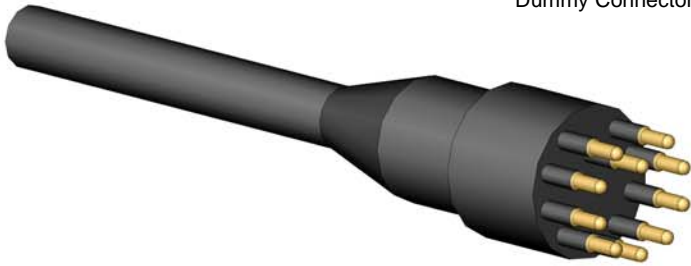

**Micro WET-CON SERIES  
MC-IL-F  
(10 - 16 contacts)**

Micro WET-CON In-Line Connector Female Socket  
Mates with MC-IL-M & MC-BH-M  
Dummy Connector: MC-DC-M

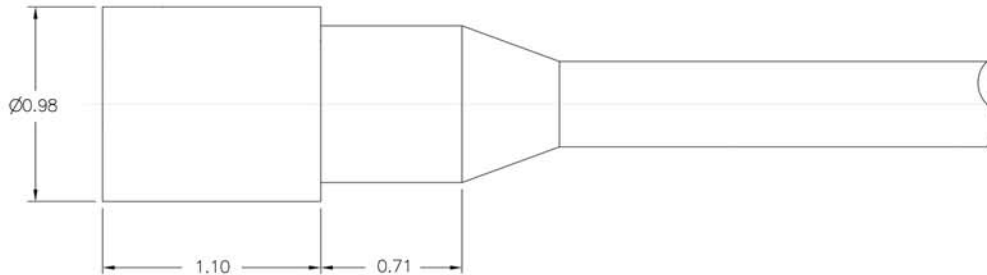
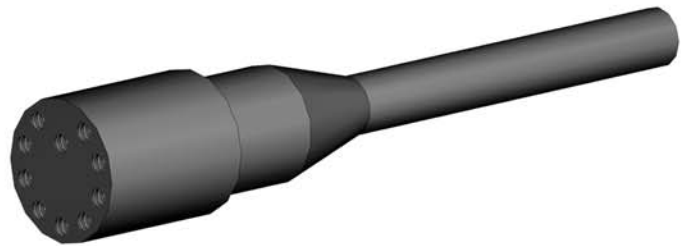

**NOTES:**

- Locking Sleeve: Optional (see page MWC 14).
- Dummy Connector: Optional.
- Dummy Shorting Plug Connector: Optional. (Shorting plugs are available should you require the ability of looping together 'like' circuits for testing purposes within the dummy. Pin to pin shorting details need to be supplied at time of order placement).
- Connectors must be lubricated prior to mating.
- \* Incorporation of special order cables will be determined on a case-by-case basis.

**Micro WET-CON SERIES  
MC-DC-M  
(2 - 8 contacts)**

Micro WET-CON Dummy Connector Male Plug  
Mates with MC-IL-F & MC-BH-F

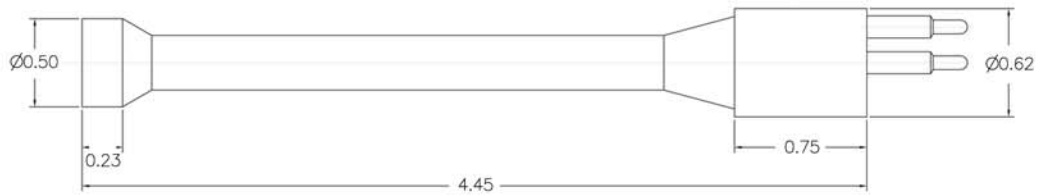

**Micro WET-CON SERIES  
MC-DC-F  
(2 - 8 contacts)**

Micro WET-CON Dummy Connector Female Socket  
Mates with MC-IL-M & MC-BH-M



**NOTES:**

- Locking Sleeve: Optional (see page MWC 14).
- Dummy Shorting Plug Connector: Optional. (Shorting plugs are available should you require the ability of looping together 'like' circuits for testing purposes within the dummy. Pin to pin shorting details need to be supplied at time of order placement).
- Connectors must be lubricated prior to mating.

**Micro WET-CON SERIES  
MC-DC-M  
(10 - 16 contacts)**

Micro WET-CON Dummy Connector Male Plug  
Mates with MC-IL-F & MC-BH-F

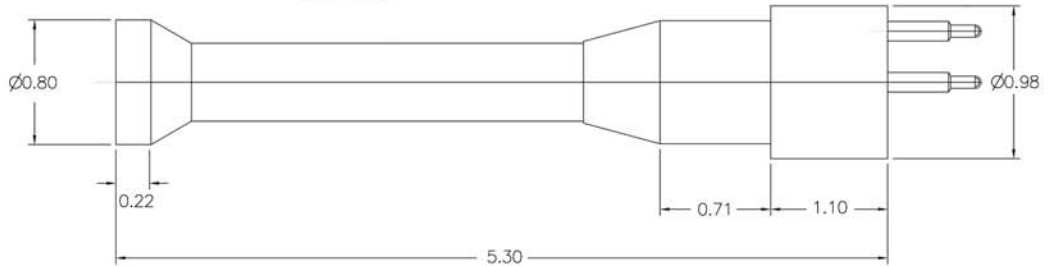
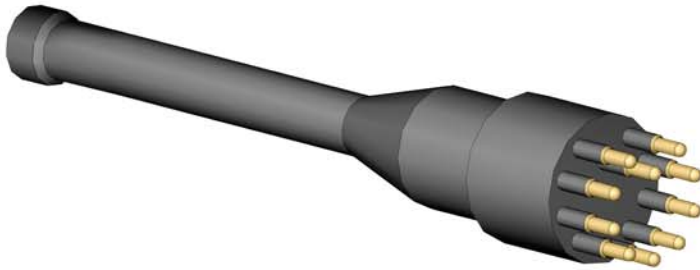

**Micro WET-CON SERIES  
MC-DC-F  
(10 - 16 contacts)**

Micro WET-CON Dummy Connector Female Socket  
Mates with MC-IL-M & MC-BH-M

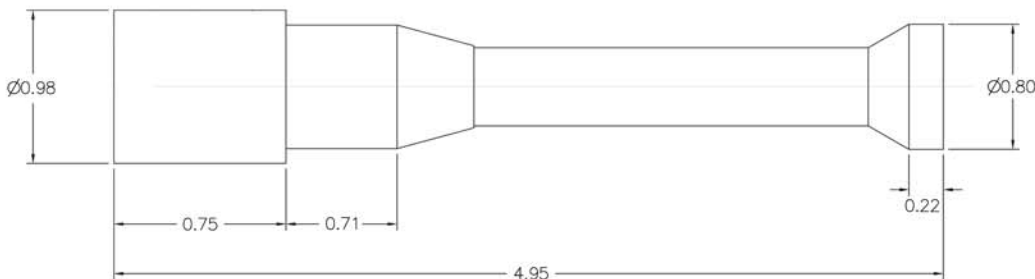

**NOTES:**

- Locking Sleeve: Optional (see page MWC 14).
- Dummy Shorting Plug Connector: Optional. (Shorting plugs are available should you require the ability of looping together 'like' circuits for testing purposes within the dummy. Pin to pin shorting details need to be supplied at time of order placement).
- Connectors must be lubricated prior to mating.

**Micro WET-CON SERIES  
MC-DLS-F  
(2 - 8 contacts)**

Micro WET-CON Dummy Locking Sleeve Female Socket

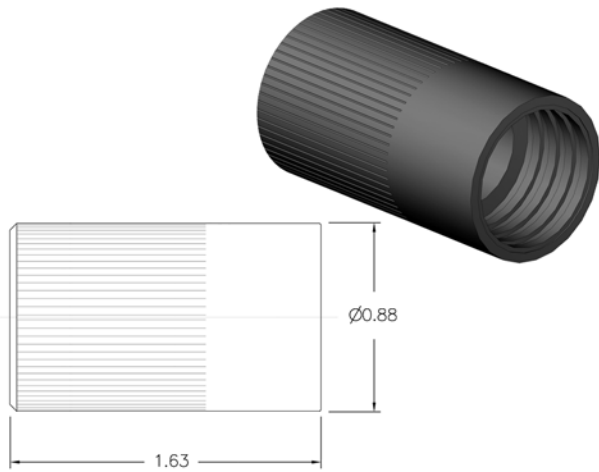

**Micro WET-CON SERIES  
MC-DLS-M  
(2 - 8 contacts)**

Micro WET-CON Dummy Locking Sleeve Male Plug

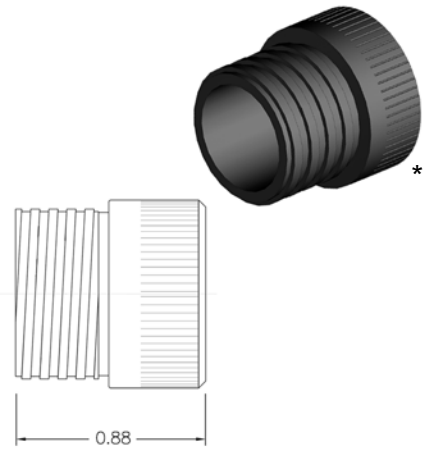

**Micro WET-CON SERIES  
DLSA-F  
(10 - 16 contacts)**

Micro WET-CON Dummy Locking Sleeve Female Socket

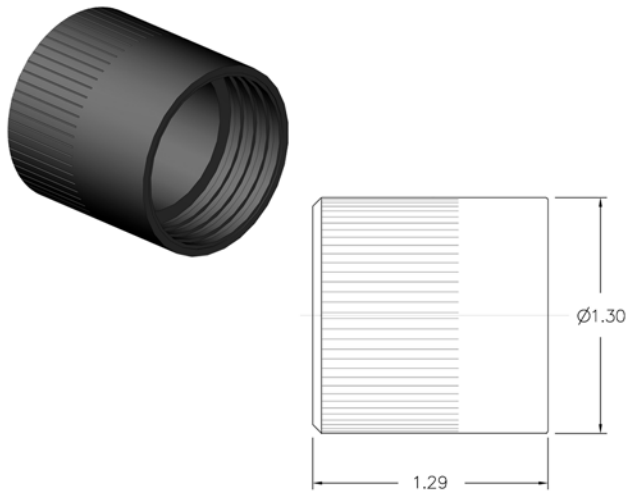

**Micro WET-CON SERIES  
DLSA-M  
(10 - 16 contacts)**

Micro WET-CON Dummy Locking Sleeve Male Plug

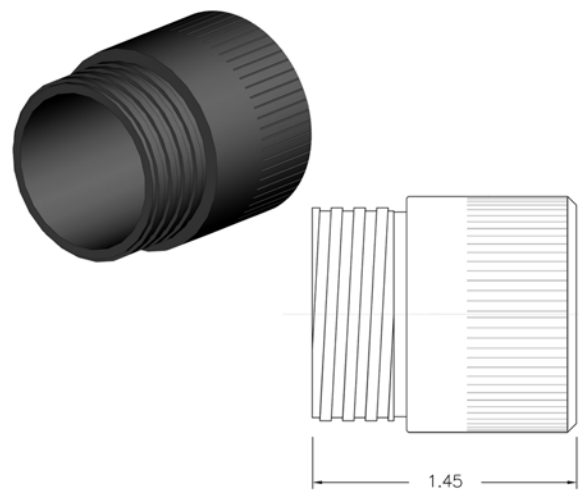

**NOTES:**

- \* Not required for 2 to 8 way Bulkhead connectors. For In-Lines only.
- Locking Sleeves: Delrin® (DuPont trademark for Acetal Resin).

**Micro WET-CON SERIES  
MC-BH-M/F  
THROUGH BORE OPTION**  
Micro WET-CON Bulkhead Connector Male/Female

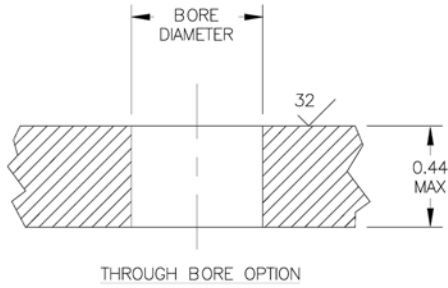

**Micro WET-CON SERIES  
MC-BH-M/F  
THREADED MOUNTING OPTION**  
Micro WET-CON Bulkhead Connector Male/Female

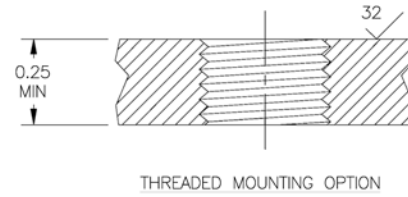

| CONNECTOR     | BORE Ø (INCHES)                           | THREAD         | SPOT FACE Ø (INCHES) |
|---------------|---|----------------|----------------------|
| MC-BH (2-8)   | 0.437 <sup>+0.015</sup> <sub>-0.000</sub> | 7/16-20 UNF-2B | 0.88                 |
| MC-BH (10-16) | 0.500 <sup>+0.015</sup> <sub>-0.000</sub> | 1/2-20 UNF-2B  | 0.94                 |

**Micro WET-CON SERIES  
MC-BH-M/F-DO (DOUBLE O-RING)  
THROUGH BORE OPTION**

Micro WET-CON Bulkhead Connector Male/Female with Double O-Ring

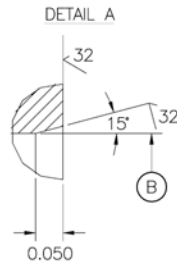
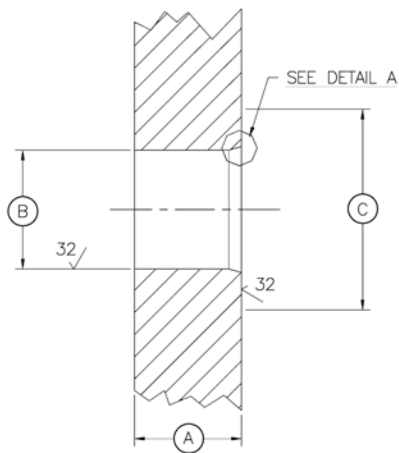

**Micro WET-CON SERIES  
MC-BH-M/F-DO (DOUBLE O-RING)  
THREADED MOUNTING OPTION**

Micro WET-CON Bulkhead Connector Male/Female with Double O-Ring

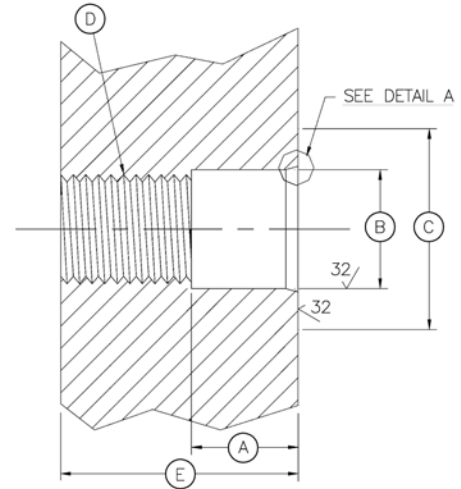

| CONNECTOR        | A - LENGTH (INCHES) | B - Ø (INCHES) | C - Ø (INCHES) | D - THREAD     | E - Ø (INCHES) |
|------------------|---------------------|----------------|----------------|----------------|----------------|
| MC-BH-DO (2-8)   | 0.425               | 0.475<br>0.473 | 0.88           | 7/16-20 UNF-2B | 0.750 MIN      |
| MC-BH-DO (10-16) | 0.500               | 0.553<br>0.552 | 0.94           | 1/2-20 UNF-2B  | 1.000 MIN      |

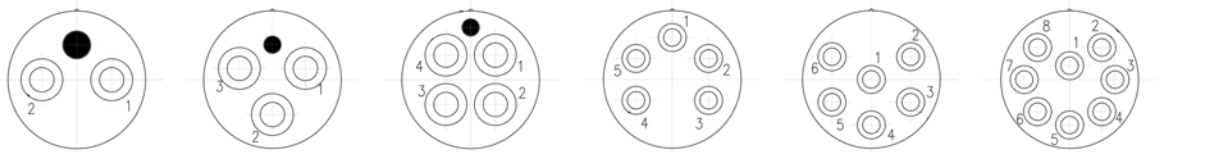
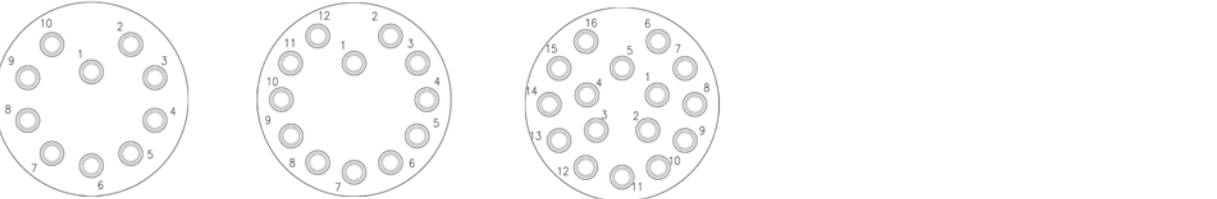
| SIZE                                 | Micro WET-CON SERIES BULKHEAD/IN-LINE CONTACT CONFIGURATIONS (MALE FACE VIEW ONLY - NOT TO SCALE)*   |
|--------------------------------------|--|
| 2-8                                  |  <p data-bbox="256 359 1377 380">MC-BH / MC-IL-2      MC-BH / MC-IL-3      MC-BH / MC-IL-4      MC-BH / MC-IL-5      MC-BH / MC-IL-6      MC-BH / MC-IL-8 **</p> |
| 10-16                                |  <p data-bbox="264 653 927 674">MC-BH / MC-IL-10      MC-BH / MC-IL-12      MC-BH / MC-IL-16</p>   |
| <p><b>KEY</b></p> <p>● GUIDE PIN</p> |  |

**NOTES:**

- \* For female face view contact configurations available please contact SEA CON®.
- \*\* Ethernet version available.





**SEA CON GLOBAL PRODUCTION**  
 Callejon Terrazos #8, Local 2-C,  
 Las Brisas 1ra. Seccion,  
 Tijuana, B.C., Mexico C.P. 22610.  
 TEL: +52 (664) 626-2726  
 FAX: +52 (664) 686-8922  
 E-Mail: sales@seaconglobal.com  
 Website: www.seaconglobal.com  
 Dial from U.S.A. TEL: +1 (619) 308-7901  
 TOLL FREE: (888) 562-7072  
 FAX: +1 (619) 308-7900



**SEA CON®**  
 1700 Gillespie Way,  
 El Cajon, California 92020, USA.  
 TEL: +1 (619) 562-7071  
 FAX: +1 (619) 562-9706  
 E-Mail: seacon@seaconworldwide.com  
 Website: www.seaconworldwide.com



**SEA CON US GULF AREA SALES OFFICE**  
 14511 Old Katy Road, Suite 300,  
 Houston, Texas 77079, USA.  
 TEL: +1 (281) 599-3509  
 FAX: +1 (281) 599-3517  
 E-Mail: gulfcoastsales@seaconworldwide.com  
 Website: www.seaconworldwide.com



**SEA CON ENCAPSULATING AND MOLDING FACILITY**  
 1718 Fry Road, Suite 250,  
 Houston, Texas 77084, USA.  
 TEL: +1 (281) 394-0216  
 E-Mail: moldingshop@seaconworldwide.com  
 Website: www.seaconworldwide.com



**SEA CON US EAST COAST SALES OFFICE**  
 50 Airport Road,  
 Westerly, RI 02891, USA.  
 TEL: +1 (401) 348-0155  
 FAX: +1 (401) 348-0227  
 E-Mail: eastcoastsales@seaconworldwide.com  
 Website: www.seaconworldwide.com



**SEA CON ADVANCED PRODUCTS, LLC**  
 1321 Nelius Road, P.O. Box 767,  
 Bellville, Texas 77418, USA.  
 TEL: +1 (979) 865-8846  
 FAX: +1 (979) 865-8859  
 E-Mail: sales@seacon-ap.com  
 Website: www.seacon-ap.com



**SEA CON BRAZIL**  
 Rua Conde de Bonfim 120 sala 212,  
 Tijuca, Rio de Janeiro,  
 Brazil, CEP: 20520-053.  
 TEL #1: +55 (21) 3592-0920  
 TEL #2: +55 (21) 3594-0920  
 CELL: +55 (21) 98849-3336  
 E-Mail: renata@seacon-ap.com  
 Website: www.seaconworldwide.com



**SEA CON (europe) LTD**  
 Seacon House, Hewett Road,  
 Gapton Hall Industrial Estate,  
 Great Yarmouth, Norfolk, NR31 0RB, UK.  
 TEL: +44 (0) 1493-652733  
 FAX: +44 (0) 1493-652840  
 E-Mail: sales@seaconeurope.com  
 Website: www.seaconeurope.com

Even though these procedures appear simple, only qualified technicians should perform the installation and maintenance. Connectors are designed for installation on one atmosphere vessels. Contact **SEA CON®** for recommendations if using compensated vessels.

**INSTALLATION PROCEDURES**

Torque values referenced in this literature assume installation into dry metal threads. For other applications, please contact **SEA CON®** for recommendations.

**BULKHEAD CONNECTOR (BC):** The BC may be installed using one of two methods. The preferred method is to spotface the bulkhead surface and thread the hole, then screw the connector by means of a nut and washer. The bored hole (or threaded hole) should be free of any "burrs" and all o-ring sealing surfaces polished to a number 32 finish. Lubricate the BC o-ring with an appropriate silicon spray or grease before installing. This lubrication should be applied to form an adequate film. Excessive lubrication is detrimental to the operation of the connector. Bulkhead nut, if used, should not be over-torqued.

**IN-LINE CONNECTOR:** Lubricate the sealing areas around the male pins, using an appropriate silicon spray, or grease lightly.

**CARE AND MAINTENANCE**

The **WET-CON** and **Micro WET-CON** connectors require very little maintenance. They are designed to be used in harsh environments and thus limited amounts of dirt and grit do not affect their performance.

It is recommended that, upon disconnecting or retrieving the system, the connectors be cleaned, to storage (if possible, remate with dummy plugs). Prior to deployment the following maintenance procedure is recommended:

1. Demate the connector set.
2. Flush connector interface with fresh water (deionized water if available), remove all dirt, grit and grease.
3. Inspect for damage in sealing areas, excessive corrosion, debonding of the cable and connector interface and cuts in the cable jacket.
4. Apply thin film of dielectric compound (DC) grease, silicon based, to sealing areas of male connector and across the face of the female connector\*. If the BC is removed from it's housing then replace facial o-ring and make sure that o-rings are lubricated and in good condition.
5. Mate the connector halves, wipe away any excess grease off the interface line of the mated set.

\* **CAUTION:** The use of some oil-based propellants in spray cans can cause conductivity problems in neoprene.

**CABLE AND CONTINUITY PRESERVATION**

Avoid sharp bends in cables. Cables subjected to vibration or exposed to seawater drag should be adequately clamped to prevent conductor fatigue and ultimate failure.

All reasonable efforts have been taken to ensure that the information contained herein is accurate at the date of publication, but no representation or warranty as to the accuracy or completeness of such information is intended or to be implied by its inclusion herein. Any and all representations and warranties pertaining to the information and products referred to herein shall be set forth in **SEA CON®** standard sales order form. In addition, **SEA CON®** reserves the right to make changes to the contents hereof without notice, therefore it is suggested that at the time of inquiry, the appropriate sales office or factory be contacted directly for verification of published specifications and products availability.

QR

© 2013 **SEA CON®**  
 ALL RIGHTS RESERVED

